

Research Sub-Program
of the
National Soil Conservation Program

FINAL REPORT

**RAINFALL SIMULATOR - GRID LYSIMETER SYSTEM
FOR PREFERENTIAL SOLUTE TRANSPORT STUDIES
USING, LARGE, INTACT SOIL BLOCKS**

Prepared by:

Bruce T. Bowman
London Research Centre
Agriculture Canada

July 1993

STUDY TEAM

Dr. Bruce T. Bowman, L.R.C.
Mr. Richard Brunke, P.Eng., L.R.C.
Mrs. LouAnn Verellen, L.R.C.
Mr. William Bennett, L.R.C.
Dr. W.D. Reynolds, C.L.B.R.R., Ottawa

SCIENTIFIC AUTHORITY

Dr. Al Hamill
Harrow Research Station
Agriculture Canada
Harrow, Ontario

ACKNOWLEDGEMENTS

The author wishes to thank each of the members of his study team for the great effort in making this study successful. He also wishes to thank Dr. Greg Wall and his research team at the Land Resource Division, Centre for Land and Biological Resource Research, Agriculture Canada, Guelph, for their assistance in obtaining the soil blocks used in this study. He also wishes to thank Dr. Martin Shipitalo, U.S.D.A., Coshocton, Ohio, for his many timely and useful suggestions in the design of the rainfall simulator and grid lysimeter apparatus.

EXECUTIVE SUMMARY

During recent years there has been increasing interest in preferential water flow through soils and the resulting potential for rapid transport of pesticides, nutrients and other solutes to tile drains and groundwater. A technique has been developed to study in detail and under controlled conditions, the preferential flow of water and solutes in large, intact soil blocks, isolated at field sites and transported to the laboratory. The soil blocks, 46-cm (18") on each side (145 kg, 320 lb) were carefully cut with a flat shovel, then encased on the vertical sides with a polyurethane foam shell (inside a plywood box) to stabilize it during transport and later experimentation. The blocks were cut at least 46 cm deep to ensure that the A/B horizon interlayer was included. Unstable, preferential water flow (and solute movement) often occurs across dissimilar interlayer boundaries in soil profiles. A boiler plate was jacked under the block to isolate it, then the entire assembly was carefully lifted onto a truck and transported back to the laboratory.

In the laboratory the block assembly was turned on its side, the base plate was removed, the base of the soil block was cleaned and an aluminum plate (60 x 60 x 2 cm) grid solution collector (containing a 10 x 10 grid of shallow, 2.38-cm square collector funnels) was sealed to the base of the polyurethane foam shell. The assembly was turned upright onto a portable dolly, then wheeled under a precision rainfall simulator, capable of uniformly delivering water to the soil surface over a 5 to 80 mm hr⁻¹ range. A grid of collector tubes below the collector plate was used to determine flow patterns of water and applied tracers. Much of the experimental data collected in this study were used to test the various components of the apparatus, as well as to characterize tracer movement through the soil blocks. Volumetric moisture content was continuously monitored at four depths in the soil block (2.5, 25, 33, 40 cm) using horizontally-inserted side-by-side pairs of Time Domain Reflectometry (TDR) probes. The probes at 25 and 33 cm were on opposite sides of the A/B horizon boundary. A tensiometer was horizontally inserted beside each TDR probe-set to monitor, in real-time, the matric potential (soil water tension).

Initial tracer tests were conducted using the bromide ion (Br^-) as a conservative, non-reactive tracer, applied to the surface of an Embro silt loam soil block that had been in alfalfa for several years. Alfalfa roots, as well as numerous earthworm channels, had penetrated the full depth of the soil block. Under steady-state rainfall inputs and independent of the input rate (from 5.6 to 19.2 mm hr^{-1}), initial traces of Br^- ion were quickly detected in the outflow from the block within 0.5 hr after the pulse had been applied to the soil surface. At saturation input rates (19.2 mm hr^{-1}), the peak concentration of the Br^- pulse in the effluent occurred 1.25 hr after initial Br^- introduction after collecting 5 L ($< 1/7$ pore vol.). At 5.6 mm hr^{-1} input, the Br^- peak was delayed until 16 hr, after collecting 11.3 L ($< 1/3$ pore vol.). Approximately 85 % of the water in the soil block was "bypassed" by the Br^- tracer. The distribution of water flow in the solution collector confirmed that extensive preferential flow of water and solute occurred in these tracer experiments.

This grid lysimeter apparatus will be used to characterize preferential water and solute movement in soil and is part of a larger collaborative effort which is investigating the same phenomena at larger scales at the same field sites where the soil blocks were obtained.

TABLE OF CONTENTS

STUDY TEAM/SCIENTIFIC AUTHORITY	2
ACKNOWLEDGEMENTS	2
EXECUTIVE SUMMARY	3
TABLE OF CONTENTS	5
LIST OF FIGURES	6
ABSTRACT	7
STUDY OBJECTIVES	8
INTRODUCTION	9
MATERIAL AND METHODS	
Soil Block Collection	15
Solution Collector Design and Installation	16
Solution Delivery (Rainfall Simulator) System	18
Soil Water Monitoring	19
RESULTS AND DISCUSSION	
Soil Block Containment	21
Solution Collection System	23
Solution Delivery System	25
Soil Water Monitoring System	26
Example of Lysimeter Operation	27
CONCLUDING REMARKS	29
FUTURE DIRECTIONS	29
REFERENCES	31
FIGURES	36

LIST OF FIGURES

- Figure 1. Solution collector with a 10 x 10 grid of 3.8-cm square funnels 1.3 cm deep, and with outer edge-flow collection channels for maintaining water and solute balance information.
- Figure 2. Schematic representation of a single funnel with drain tube assembly.
S.S.= stainless steel.
- Figure 3. Detailed schematic of the mounted solution collector and vacuum chamber.
- Figure 4. Schematic of the soil block positioned within the solution delivery-collection-monitoring system.
- Figure 5. Response of tensiometers to a constant simulated rainfall of 19.2 cm min^{-1} on saturated intact soil block. Quasi-steady state, saturated flow within the block occurred after 2000 min.
- Figure 6. Comparison of measured and predicted bromide breakthrough curves (BTC) resulting from the addition of a square wave pulse (275 mL) of KBr tracer ($C_0 = 1031 \text{ mg L}^{-1}$). The $t = 0$ time corresponds to $t = 2040$ min in Figure 5.
- Figure 7. Distribution of water flow within the solution collector for the quasi-steady, saturated flow conditions of Figure 5.
- Figure 8. Comparison of measured and predicted bromide breakthrough curves (BTC) resulting from the addition of a square wave pulse (275 mL) of KBr tracer ($C_0 = 1031 \text{ mg L}^{-1}$). Input application rate = 5.6 mm hr^{-1} .
- Figure 9. Distribution of water flow within the solution collector for the quasi-steady, saturated flow conditions of Figure 8.

ABSTRACT

A grid lysimeter system, sample collection, containment and storage techniques were developed for detailed laboratory studies of water and solute movement through large, intact soil blocks. Procedures are given for field-isolation and containment of 46-cm intact soil cubes within a polyurethane foam shell. The polyurethane formed a stable, intimate bond with the soil, was impermeable to water and was strong enough to support a large soil block, but sufficiently elastic to accommodate shrink-swell of the soil with changing water content without rupturing. In the laboratory, the soil blocks were instrumented with solution delivery, collection and monitoring systems. A dripper-based rainfall simulator was used to deliver steady rainfall rates ranging from 4.8 to 30 mm hr⁻¹ with a uniformity coefficient > 95%. The solution collection system consisted of a 10 x 10 grid of 3.8 x 3.8 x 1.3-cm deep cells in an aluminum block which individually drained into collection tubes housed within a vacuum chamber. The collection grid permitted characterization of spatial and temporal movement of water and solute through the soil block. The solution monitoring system consisted of side-by-side pairs of tensiometers and TDR probes inserted horizontally through the foam shell at four depths in the soil block. To test the operation of the lysimeter system, a bromide tracer breakthrough curve was generated using the intact soil block, at a constant simulated rainfall rate of 19.2 mm hr⁻¹. The flow data indicated that 85% of the water in the block was "bypassed" by the bromide, and that over 99% of the water flow passed through only 26% of the basal area of the soil block. The pattern of water flow in the solution collector was random with no evidence of preferential flow along the interface between the soil and the outer polyurethane shell. These results indicate that the lysimeter system was operating effectively and as required.

STUDY OBJECTIVES

The following study objectives were developed in the original N.S.C.P. proposal:

1. Develop *in situ* macropore sampling techniques for quantifying macropore water flow, using rainfall simulation to control water inputs.
2. Determine relationship between rainfall intensity and the threshold or onset of macropore flow in soil under different tillage/cropping practices.
3. Determine temporal and spatial variability of macropore flow in soil profiles under different tillage and cropping practices, and to investigate the interrelationships between tillage/cropping practices and macropore flow patterns in soil profiles.
4. Correlate macropore flow patterns with microfabric measurements of macropores using resin-impregnated soil blocks and autofluorescing dyes followed by image analysis.

The original project was designed around a two-year field program. However, a four-month startup delay in 1991 (until August) precluded doing field studies in 1991, and necessitated changes in the project design and objectives. The revised objectives became:

1. Develop techniques for isolating and transporting large, undisturbed soil blocks for detailed laboratory investigations of preferential water and solute transport.
2. Develop and test a precision rainfall/grid lysimeter apparatus to investigate spatial and temporal variability of water and solute transport in intact soil profiles, using a variety of tracer compounds.

INTRODUCTION

Agricultural soils exhibit a great diversity in the nature of their porosity (amount, pore sizes, configuration, distribution), which is used as a measure of soil structure (Daniels and Sutherland 1986), and consequently of soil tilth. A considerable fraction of this pore space consists of interconnected pores, creating somewhat continuous, tortuous channels capable of conducting water downwards in soil profiles. The larger pore channels, referred to as macropores, can significantly influence water movement in soils. The definition of macropores and macroporosity has varied considerably in the literature, and has been extensively reviewed by Beven and Germann (1982). Macropores are quite diverse in their origins, which include earthworm burrows, decaying plant root channels, cracks, interpedal planes, or packing voids (Logsdon *et al.* 1990). Macropores derived from earthworm activities are the most important pathways for solute movement because they may last 50 to 100 years (Lee 1985).

Macropores can rapidly conduct significant amounts of water to considerable depths in soil profiles over relatively short time periods during rainfall events. Ehlers (1975) reported a maximum infiltrability of more than 1 mm min^{-1} in untilled soil from macropores accounting for only 0.2 vol.%, with maximum penetration of 180 cm. One extreme value of macropore flux has been reported by Peterson and Dixon (1971) of 0.5 m sec^{-1} for a single macropore of 6 mm diameter. Watson and Luxmore (1986) reported that under ponded conditions on a forest floor, 90% of the water flux was through 0.32% of the soil volume. Macropore water conduction occurs whenever the rainfall intensity exceeds the infiltration rate (hydraulic conductivity) of the soil (Ehlers 1975).

The presence of soil macropores is of mixed benefit in soil tillage/cropping management schemes. On the positive side, development of active macropore channel networks in soil, promoted by practices which do not disturb the soil surface (i.e. no-tillage), increases the water infiltration rate into the soil (Field *et al.* 1984; Germann and Beven 1981), thereby reducing surface water runoff volumes and erosion potential. If the macropores are developed as a result of earthworm activities, further enhancements of soil aggregate stability and tilth can be expected. In addition, mixing of organic materials (surface residues, earthworm casts, etc) with the mineral fraction by earthworms may promote increased water holding capacity (Kemper *et al.* 1987). This in turn can increase the water residence time in the upper horizon (Steenhuis *et al.* 1990), thereby acting as a buffer during short, intense rainfalls.

On the negative side, macropores can rapidly transport significant amounts of surface-applied chemicals (fertilizers, pesticides, manure) to tile drain systems, especially during intense rainfalls if they occur during the week or so following application (in effect contributing to surface transport of solutes). Over longer time spans, solutes may reach groundwater supplies as a result of macropore flow. Macropores having the greatest impact on agricultural practices, with respect to water quality, are those channels which are continuous to the soil surface. Thus tillage/cropping practices strongly influence the importance of macropores at any given time.

Macropore channel networks in soils have proven difficult to characterize, from the standpoint of predicting solute transport, because of their temporal and spatial variability throughout the upper soil horizons (Everts and Kanwar 1990). Often *in situ* techniques used to sample the hydraulic properties of

the macroporous soil operated on sampling elements that were too small to accurately assess the macroporous nature of the soil i.e. tensiometer cup samplers (Field *et al.* 1984) or suction lysimeters.

There have been differing approaches to characterizing macropore flow using undisturbed blocks of soil, which were usually removed from the original site and instrumented with solution delivery, collection and monitoring systems (Buchter *et al.* 1984; Lewis *et al.* 1990; Murphey *et al.* 1981; Tindall *et al.* 1992). Inherent in the successful use of this method, however, are several difficult and critically important steps, including the choice of adequate core/block size, the use of effective techniques for isolating, transporting and storing the core/block, and the instrumentation of the core/block with appropriate and effective solution delivery, collection and monitoring systems. Many different criteria, approaches and techniques have been applied over the years to accomplish these steps. Some of the more recent of these are reviewed briefly below.

Many studies have concluded that preferential water and solute movement in undisturbed field soils is caused primarily by the extreme variability in the sizes, shapes, connectivity and distributions of soil pores, and by "fingering" or "wetting front instability" at soil layer or horizon boundaries (Baker and Hillel 1990; Selker *et al.* 1991; Steenhuis and Parlange 1991). Because of this, Bouma and coworkers (Bouma and Wösten 1979; Bouma *et al.* 1981), and others have suggested that accurate representations of preferential flow behaviour can only be obtained from intact soil cores and blocks that contain the major soil horizon and layer boundaries, and which are 13 L or more in volume. Such large intact soil volumes require elaborate and specialized techniques for successful isolation, transport and storage.

Murphey *et al.* (1981) successfully accomplished the isolation, transport and storage of an intact 25.4 cm cube of weakly cohesive soil by first excavating the block using shovels, trowels and knives, then coating all surfaces of the block with layers of polyester resin and fiberglass cloth, and finally affixing the block to a wooden pallet. Although these procedures were themselves found to cause minimal alteration of the antecedent soil structure and water content, subsequent opening of the resin-cloth shell required very careful operation of a bandsaw to prevent soil smearing, compaction, etc. Buchter *et al.* (1984) were faced with obtaining large soil blocks from a stony soil profile and chose to encase their pedestal in concrete, using a paraffin seal between the soil and concrete. Besides the obvious inconvenience of the added weight and bulkiness of the concrete, they had to freeze the encased block at -22°C , then cut the block to the desired size with a liquid nitrogen cooled diamond saw in order to minimize disturbance and smearing of the soil during the cutting process.

The grid lysimeter studies of Andreini and Steenhuis (1990) and Ogden *et al.* (1992) made use of soil blocks approximately 35 cm square x 34 to 46 cm deep. They placed prefabricated plywood boxes over the blocks and sealed the gap between the box and block with plaster of paris. Although plaster of paris forms an excellent initial encasement, it has the important disadvantages of forming shrinkage cracks upon drying, and of being permeable to water. In addition, fully cured plaster of paris is too rigid to accommodate even modest shrink and swell of the soil block during wetting-drying cycles, which often results in further cracking as well as breakage of the soil-plaster of paris seal.

Lewis *et al.* (1990) used triple-expanding polyurethane foam to form a seal between PVC (polyvinylchloride) pipe (46-cm. diam.) and free-standing circular soil pedestals 60 to 90 cm in length. The foam formed a very effective, light-weight, inert, water-proof seal around the pedestal. Although they intended to use the cores in leaching studies, no details were provided. Shipitalo *et al.* (1990) also used liquid polyurethane foam to encase their 30 x 30 x 30-cm soil blocks, using a plywood box for the outer form.

Recently Tindall *et al.* (1992) hydraulically pressed a stainless steel core barrel (30-cm diam. x 38-cm long) into the soil to isolate a soil pedestal. Important limitations of this approach, however, are potential compaction and macrostructure collapse in the soil due to frictional resistance and vibration during the core insertion process. We have frequently noted in pan lysimeter studies, for example, that although the soil matrix tends to have considerable resistance to deformation forces, the soil macrostructure is quite fragile and easily damaged with very little penetrating force. After Tindall *et al.* (1992) isolated their pedestal, they removed the core barrel and wrapped the pedestal in sheet metal secured with hose clamps.

In order to study spatial and temporal variability of water and solute movement through intact soil blocks, it is necessary to interface the block with solution delivery and collection systems. Andreini and Steenhuis (1990) constructed a grid collector consisting of a 6 X 6 array of 2.5- x 2.5-cm square cells, surrounded by two courses of 5- x 5-cm cells. The grid was filled with 1-cm diam. chipped limestone, used for both support and as an interface to conduct percolate away from the base of the block. Their solution delivery device was a rainfall simulator, which consisted of a trolley riding back and forth on a set

of rails, with water dripping from a single 18-gauge catheter mounted on the trolley. The grid collector used by Shipitalo *et al.* (1990) consisted of an 8 x 8 array of 3.75- x 3.75-cm square funnels, covered by a fine screen to support the soil block. They delivered solution to the block via a rotating syringe-grid applicator similar to the rainfall simulator used by Römken *et al.* (1975). Tindall *et al.* (1992) used a ceramic plate system to collect soil solution because they were not investigating within-block variability of water and solute flow. A slurry of diatomaceous earth was used to assure good interfacial contact between the soil and the ceramic plate.

In this report, we describe techniques for isolating, transporting and storing large, intact soil blocks (46-cm cubes) weighing about 145 kg, and for instrumenting these blocks with tensiometers and TDR probes for non-destructive in-situ measurement of matric potential and volumetric water content, respectively. We also describe a rainfall simulator-type solution delivery system, and a grid-type solution collection system that allows vacuum to be applied to control the soil pore sizes participating in water and solute flow. Finally, we used water flow distributions, tracer breakthrough curves and in-situ measurements of matric potential and volumetric water content to demonstrate the effectiveness of the designs.

MATERIALS AND METHODS

Soil Block Collection

Soil blocks (46-cm cube) were carefully isolated from a soil profile using a flat shovel to cut straight, smooth surfaces. An open-ended plywood box (51-cm cube I.D., 2-cm wall thickness lined on the inside with polyethylene film) was positioned over the block, maintaining a uniform space of about 2.5 cm on each vertical side. A polyethylene-covered "protector plate" 46 X 46 X 10 cm high, was positioned on the top of the soil pedestal to prevent expanding foam from flowing onto the soil surface. One-L volumes of both polyurethane foam components (isofoam[®] A and B, I.P.I. Div. of Kingsley and Keith (Canada) Inc.) were mixed vigorously for 10 s, then poured into the cavity between the soil block and the plywood box. Within 10 min, the foam had expanded and hardened sufficiently to remove the protector plate and to trim the excess foam from the top of the box with a corrugated blade. Small bags of vermiculite pellets were carefully packed onto the top of the block to maintain the antecedent soil surface conditions during transport and manipulation, then a plywood cover was screwed onto the top of the box.

A 1-m² area of soil adjacent to the block was excavated to the full depth of the block so that its base could be cut off using an hydraulically operated, 76 x 71 x 0.3 cm, "cutoff" plate. Adjustable angle iron strips, separated by the width of the plywood box and parallel to the insertion direction, were bolted to the cutoff plate to stiffen it and to prevent bending when lifting the soil block out of the pit. The angle iron also acted as guides for the cutoff plate during the insertion process. Prior to cutoff plate insertion, several

3-cm diameter horizontal holes were bored beneath the pedestal at right angles to the direction of plate insertion. This served to loosen the soil below the block thereby minimizing damage to the block base during the insertion process. A backhoe bucket was used to prevent movement of the block during plate insertion. After the cutoff plate was inserted, the entire box-cutoff plate assembly with its contained soil block was lifted onto a wooden skid covered with a foam cushion and transported to the laboratory for storage at -5°C .

Solution Collector Design and Installation

The solution collector consisted of an anodized aluminum plate 60 x 60 x 2 cm, into which was machined a grid of 10 x 10 (100) square funnels, (3.8 x 3.8 x 1.3 cm deep), each leading to a central tubular drain hole (Leesta Industries, Montreal, QUE) (Fig. 1). To avoid possible edge effects, the grid of funnels was confined to the centre 38- X 38-cm area of the soil block. The flow in the 4-cm wide boundary area between the edges of the funnel array and the edges of the soil block was also collected via four, 6.35-cm wide, sloping edge-flow channels machined into the edges of the solution collector (Fig. 1). Collection of the edge flow ensured that vertical rectilinear flow within the soil block was maintained, and that water and solute mass balances could be calculated. A stainless steel (S.S.) drain-tube (29 X 4 mm i.d.), a fine S.S. screen and a retaining ring were press-fitted into each funnel drain hole (Fig. 2). The grid funnels and edge-flow collection channels were filled with a borosilicate glass sphere slurry (53 to 105 μm sphere size), and allowed to drain for a couple of hours prior to installation of the collector onto the soil block.

The solution collector was attached to the block by first rotating the block on its side (using a rotary clamping frame and a hydraulic shop crane) and removing the cutoff plate to expose the soil at the block base. Approximately 1.5 cm of soil was cut away using a coarse tooth pruning saw to expose a fresh, uncompacted soil surface which was not smeared or structurally damaged by the cutoff plate. A vacuum cleaner was then used to remove loose soil and to reopen worm holes, root channels, cracks and other macrostructure. All visually significant macrostructure in the block base was then recorded for future reference by tracing their shapes and positions on an oriented, clear, 4-mil acetate sheet. To ensure good hydraulic contact between the soil and the collector, the soil surface was levelled using a borosilicate glass sphere (53 to 105 μm sphere size) slurry to fill in depressions, etc., and then the collector, filled with the same glass sphere slurry, was brought in contact and secured. The soil block-grid assembly was then rotated upright, mounted on a mobile trolley (0.9 m high), and the outer plywood box dismantled to expose the polyurethane foam shell around the block. A bead of exterior silicone caulking was then applied to ensure an air-tight seal between the foam shell and the solution collector (Fig. 3).

An acrylic vacuum chamber (51 x 51 x 24 cm deep) was sealed to the underside of the solution collector using a neoprene gasket and clamps (Fig. 3). The vacuum chamber allowed, through adjustment of the applied vacuum, control of the range of soil pore sizes participating in water and solute flow (i.e. the degree of unsaturation during unsaturated flow). A removable door on the front of the vacuum chamber permitted quick access to a percolate collector tray containing a 10 x 10-array of Pyrex glass culture tubes (150 x 25 mm) which were arranged on the same spatial grid as the drain tubes in the solution collector (Fig. 3). Water volumes delivered by the four edge-flow collection channels were bulked into a separate

container (Fig. 3). The vacuum in the vacuum chamber was controlled by a precision sub-atmospheric vacuum-pressure regulator (110 kPa vacuum to 0 to 34.5 kPa pressure, Model 44-20, Moore Instruments, Brampton, ON) connected to the building vacuum system. A water-filled manometer was used for precise monitoring of the applied vacuum (0 to 20 cm water). Provision was also made for sampling of individual funnels in the solution collector via an access tube through the side of the vacuum chamber to a secondary vacuum chamber. This permitted continuous measurement of water and solute flow in individual solution collector funnels. After the vacuum chamber was installed, the trolley-mounted soil block was wheeled into the solution delivery-collection-monitoring system (Fig. 4).

Solution Delivery (Rainfall Simulator) System

Water was delivered to the soil block surface via a 10 x 10-grid of syringe needles (drippers) arranged on the same 3.8-cm spacing as the solution collector funnels (Fig. 4). The drippers were attached on the underside of a S.S. reservoir (50 x 50 x 1.25-cm deep) using male Luer-Loc[®] to 10/32 standard thread adapters (Popper and Sons, New Hyde Park, NY). Either 22-gauge (0.406 mm bore), 25-gauge (0.254 mm bore), or 27-gauge (0.203 mm bore) drippers were used for water delivery, depending on flow requirements. In order to provide as uniform coverage as possible, the entire dripper grid was rotated (1.25 cm radius) and X-Y translated (2.5 cm translation limits) using variable speed DC motors. The dripper grid was supported approximately 20 cm above the soil surface, and water was applied over the entire 46- X 46-cm soil surface. Reverse osmosis, deionized water spiked with 0.005 M CaSO₄ (to minimize clay deflocculation in the soil) was delivered to the dripper grid through a surgical rubber tube (3.2

mm I.D.) using a variable speed peristaltic pump (0.15 to 1020 mL min⁻¹). Parallel in-line glass-fiber filters (0.7 µm) prevented suspended particulates from clogging the drippers. The upper surface of the dripper reservoir was dome-shaped to facilitate bleed-off of air exsolved from solution. For some experiments, the soil surface was covered with a nylon mesh (53 x 53 µm openings), and the mesh covered with a levelled, . 2 cm thick layer of sand (425 to 840 µm). This was done when it was desired to maximize the uniformity of solution infiltration across the soil surface by minimizing the effects of surface irregularities.

Soil Water Monitoring

Soil water matric potential and volumetric water content were monitored in-situ at several depths in the soil block (Fig. 4) in order to characterize soil water status and its change during experimentation, and to determine the hydraulic properties of the soil (i.e. the soil water characteristic and the hydraulic conductivity-pressure head relationship). Matric potential (also referred to as "tension" and "pressure head") was measured using fast-response tensiometers consisting of acrylic tubing (22 cm long, 0.95 cm o.d., 0.32 cm wall) fitted on one end with a ceramic cup (SoilMoisture Equipment Corp., 3 cm long, 0.95 cm o.d., 0.159 cm wall, high flow, 1 bar bubbling pressure), and on the other with a pressure transducer (Motorola, temperature compensated 0 to 10 kPa differential pressure sensor, ±0.15% full scale linearity) wired directly to a microcomputer.

Volumetric water content was measured using the TDR method (Topp et al., 1993) and parallel-pair probes (0.3 cm thick, 46 cm long, stainless steel, 2.5 cm spacing between probes) connected to a

cable tester (Tektronix, 1502B). The tensiometers and TDR probes were installed horizontally through the foam wall of the soil block as side-by-side pairs at four depths below the soil surface (2.5, 25, 33, 40 cm in the example discussed below). The depths were chosen to allow monitoring near the soil surface, near the base of the Ap horizon, near the top of the B horizon, and near the base of the soil block. The tensiometers were inserted a distance of 22 cm from the side of the soil block to avoid possible edge effects, and to provide a "mid block" matric potential. The TDR probes extended to within 5 cm of the opposite wall of the block (probe length of 41 cm within the soil) to yield an "average" block water content at each of the selected depths.

RESULTS AND DISCUSSION

Soil Block Containment

Containment of an undisturbed soil block is one of the most critical and fundamental steps in constructing a grid lysimeter system. Many different approaches to block containment have been tried with varying degrees of effectiveness and convenience, as noted in the introduction. The material used to contain the block should ideally have the following properties: i) it should form a stable, intimate bond with the soil, ii) it should be water-repellent, neither degrading nor softening with extended exposure to high moisture contents, iii) it should have sufficient strength to support the soil block, while being sufficiently flexible to allow the block to swell and shrink with changing moisture contents without rupturing the bond with the soil, iv) it should not shrink nor crack with aging, v) it should be an electrical insulator to avoid interference with voltage-based instrumentation (e.g. TDR probes) and, vi) it should neither adsorb materials from the soil

nor release materials to the soil. Our experimentation thus far suggests that the polyurethane foam used (i.e. isofoam®) satisfies the first five criteria (discussed further below). We do not as yet have information on the chemical sorption and release characteristics of the foam.

The isofoam consistently produced uniform foam shells, providing no loose soil fell into the reacting liquid foam during the expansion phase, and providing the liquid foam was uniformly distributed around the base of the block. It is important that the shell be created in one operation, as freshly reacted foam does not adhere well to cured foam (M.J. Shipitalo, personal communication, 1991), and for this reason it was preferable to use a bulk source of foam rather than small aerosol cans. The moderate pressures created by the foam during expansion (maximum expansion of about 12 fold occurred at 15 to 20°C) caused about a 0.5 cm penetration of foam into the soil, resulting in a very strong, water-tight foam-soil bond. Rupture of the foam-soil bond was not observed, provided that the soil block did not completely air dry. For this reason, it is advantageous to obtain the soil blocks at relatively low moisture content so that any further drying would not likely cause shrinkage problems with the foam shell. The foam was usually hard enough for easy trimming with a knife within 10 min of mixing, and the foam did not appear to deform, soften, shrink, crack or degrade with time. The dielectric constant of the cured foam is sufficiently low (. 1.2) as to not interfere with water content determination using TDR.

It was important that earthworm activity cease at the time of block collection, since it was not possible to use the soil blocks immediately following their collection (we collected either pairs or triplicates), and since it was necessary to run a number of successive water flow experiments on each block

over a period of weeks to months. It was decided that freezing at -5°C was the simplest and most effective means to stop adult earthworm activity, recognizing that freezing-induced changes might take place in the soil itself. As the soil was moderately dry at collection time (i.e. well below field capacity), it is believed that a single freezing would not result in significant and/or "un-natural" changes in the soil structure. Earthworm populations may be maintained in some future studies to examine their role on water and solute flow over a period of time.

Solution Collection System

Important features of a grid-type solution collector for measurement of saturated-unsaturated water and solute movement through a lysimeter include: i) minimal flat area on the grid surface which can cause impeded drainage and perturbed (non-rectilinear) flow at the soil interface; ii) minimal volume in each collector cell to minimize solute mixing within the collector; iii) contact material between the collector and the soil that has appropriate air entry and saturated hydraulic conductivity values, and that neither reacts with the solutes being studied nor causes significant additional dispersion of the solute as it passes from the soil to the collection tubes; and iv) precise and accurate control of the matric potential at the soil-collector interface so that the size range of soil pores conducting water and solutes can be controlled and characterized.

The ideal of zero flat area on the collector grid was not feasible due to the practicalities of collector construction. However, the present design with 3-mm radius corners at the top of each square funnel

produced only 0.088 cm² of flat area per four-unit set of funnels (Fig. 1 insert). This resulted in a total flat area at the soil-collector interface of only 8.8 cm², which was only 0.6 % of the total collector surface. In contrast, many earlier collector designs had total flat areas that comprised more than 13 % of the collector surface (e.g. Andreini and Steenhuis, 1990; assuming a tubing wall thickness of 3 mm). Each cell (i.e. square funnel) in our collector (Fig. 2) has a volume of only 9-ml, whereas other designs often have volumes of over 30-ml per cell (e.g. Andreini and Steenhuis, 1990), and thus much greater potential for significant within-cell mixing of solute.

The borosilicate glass spheres used as contact material between the solution collector and the soil have an air entry value of approximately 60 cm of water and a saturated hydraulic conductivity of about 0.03 cm s⁻¹. This air entry value is sufficient to study unsaturated water and solute flow over the porewater tension range that involves soil macropores (i.e. tensions < 20 cm), and the hydraulic conductivity value is large enough to not be limiting for most agricultural soils. The glass spheres were also found to be virtually non-reactive to most tracers (e.g. chloride, bromide, difluorobenzoates) and many pesticides (e.g. atrazine, metolachlor), and to have a saturated dispersivity of only 0.023 cm (53 to 105 µm range in sphere diameters). This material should therefore not add significant artifact effects onto the water and solute transport behaviour produced by the soil block.

The vacuum system attached to the underside of the solution collector provided precise, accurate and stable control of the matric potential (tension) at the soil-collector interface through the combined use of a precision vacuum-pressure regulator and a water monometer. The system was capable of maintaining

tensions between zero (ambient atmospheric pressure) and 60 cm of water (the air entry value of the glass spheres contact material) for extended periods of time with a precision of ± 0.2 cm of water. This high degree of control is essential for detailed studies of soil macropores, which are known to exert a strong influence on water and solute movement, but which are believed to be operative only at porewater tensions less than about 15 to 20 cm of water.

Solution Delivery System

A new needle-based rainfall simulator was developed for this study because none of the existing spray nozzle or syringe-needle systems that were considered could deliver the desired range of rainfall rates (5 to 30 mm hr⁻¹) with the desired degree of uniformity (uniformity coefficient, $C_u > 95\%$, see below) over an extended period of time. The main problems with the existing designs included dripper (needle) plugging with exsolved air and/or suspended particles, and increasingly erratic solution delivery due to aging and binding of simulator components (e.g. syringe plungers). These problems were reduced by developing a dripper reservoir that could accept a range of needle sizes to produce a range of drop sizes, by use of a precision variable-speed peristaltic pump to provide a range of uniform pumping rates, by incorporation of provisions for bleeding off exsolved air and for filtering out suspended particulate, and by use of both rotation and X-Y translation of the dripper grid to produce more uniform surface coverage (Römken et al., 1975). These features combined to produce rainfall uniformity coefficients, C_u (Andreini and Steenhuis, 1990) of $> 98\%$ for rainfalls ranging from . 5 mm hr⁻¹ to . 25 mm hr⁻¹ over time periods of up to 72 hr, where:

$$C_u = 100 \{1.0 - (|x|/m \cdot n)\} \quad (1)$$

where $|x|$ = absolute deviation of the individual rainfall rates from the mean

m = mean rainfall rate

n = number of observations of rainfall rate

Soil Water Monitoring System

The tensiometer and TDR instrumentation was installed to allow nondestructive, in-situ measurement of porewater matric potential (tension), volumetric water content, the soil water characteristic, and the hydraulic conductivity-pressure head relationship. Due to the sensitivity of tensiometers, monitoring of matric potential is the most precise way of determining if unsaturated flow is transient or steady state, especially in the macropore flow range (tensions < 20 cm) where the soil is near-saturated and water content is nearly constant. Matric potential is also required for the determination of hydraulic head gradients and the range of pore sizes conducting solution during unsaturated flow. The TDR instrumentation provides measurements of average volumetric water content within a relatively large volume of soil (approximately 100 cm³ in this study), which in turn allows more relevant calculation of average linear porewater velocity and solute velocity, and percentages of soil water "bypassed" by solutes. The combined use of tensiometers and TDR probes to determine the soil water characteristic and hydraulic conductivity relationship allows the water storage and transmission characteristics of the soil to be determined, which are required (among other things) for simulation modelling and for calculating macropore volumes. Since

the tensiometers had an equilibration time of only 2 min (90 % response), they should be able to provide an accurate representation of even fairly rapid changes in matric potential. The TDR technique can measure volumetric water content with a full-scale accuracy of 1 to 2 % (Topp et al., 1993), which should be more than adequate for our purposes.

Example of Lysimeter Operation

An intact 46 x 46 x 44.05 cm deep block of structured Embro silt loam soil (gleyed Grey Brown Luvisol) was collected and instrumented as discussed above. The tensiometer and TDR probes were installed as side-by-side pairs at depths of 2.5, 25.0, 33.0 and 40.0 cm below the soil surface, the middle two pairs lying on either side of the boundary between the Ap and B horizons. A constant simulated rainfall of 19.2 mm hr⁻¹ was applied until quasi-steady saturated flow throughout the block was achieved (at approximately t = 2000 min), as indicated by nearly constant and positive tensiometer readings (Fig. 5). (The solution collector vacuum chamber was set at ambient atmospheric pressure). At t = 2040 min, a 275 cm³ slug of KBr tracer solution (C₀ = 1031 mg L⁻¹ bromide) was added via the rainfall simulator as a square wave pulse (pulse duration of 4.6 min), and then followed by tracer-free rainfall. Both the tracer pulse and the following tracer-free solution were applied at the same rate as the original rainfall (i.e. 19.2 mm hr⁻¹), and with only two, 5-s interruptions in flow. Collection of effluent from the base of the soil block was initiated at t = 2040 min and continued until the termination of rainfall at t = 3060 min (Fig. 5). The effluent was analyzed for bromide concentration and areal distribution of water flow within the collection area.

The bromide breakthrough curve (BTC) was found to be extremely asymmetric, with bromide first appearing in the effluent (bromide concentration of 0.25 mg L^{-1}) after only 15 min and the peak concentration (22 mg L^{-1} bromide) appearing after only 75 min (Fig. 6). In contrast, the BTC predicted by an analytical solution of the convection-dispersion equation (Kirkham and Powers, 1972) is nearly symmetrical with the 0.25 mg L^{-1} bromide concentration not appearing until 300 min, and the 22 mg L^{-1} (peak) concentration not appearing until 495 min (Fig. 6). These discrepancies suggest extreme preferential flow of the bromide through the soil block. Using the average TDR-measured volumetric water content in the soil block (0.365 ± 0.050) and the calculated velocity of the measured BTC peak, approximately 85% of the water in the soil block was "bypassed" by the bromide.

The same infiltration experiment as in Figure 5 was repeated using a square-wave bromide pulse at only 5.6 mm hr^{-1} input rainfall rate. The measured bromide tracer peak now occurred at $t = 930 \text{ min}$ (compared with 75 min at 19.6 mm hr^{-1}) and was more symmetric. The BTC for bromide ion predicted by the convection-dispersion equation now peaked at $t = 1590 \text{ min}$, compared with 300 min at the greater input rate, and the maximum bromide concentration decreased to about 10 mg L^{-1} , compared to 22 mg L^{-1} .

The distribution of water flow in the solution collector confirmed that extensive preferential flow of water and solute occurred. Both Figures 7 and 9 show that over 99% of the water flow was conducted through only about 26% of the basal area of the block regardless of the input rainfall rate. In addition, 13 of the solution collector cells conducted water at rates exceeding 0.1 cm min^{-1} , while 49 cells flowed at less

than 0.6 mm hr^{-1} . The distribution of flow rates through the solution collector appeared to be random with no evidence of preferential flow along the interface between the soil and the foam shell.

Although this example is somewhat specific, it demonstrates nonetheless that the grid lysimeter system has the desired measurement capabilities, and that the solution delivery, collection, monitoring and soil containment components of the system are operating as required.

Concluding Remarks

Elucidation of the mechanisms controlling the preferential movement of water and solutes through soil require extensive and careful experimentation on intact soil samples that are large enough to be representative of true field conditions. Detailed and accurate measurements through space and time of the water and solute storage and transmission properties of the soil must be made, and the initial and boundary conditions relevant to water and solute movement must be both known and controllable. The grid lysimeter system and the sample collection, containment and storage techniques described in this report are an attempt to satisfy these requirements.

uture Directions

This study has focussed on the careful validation of the various components of the grid lysimeter system to accurately characterize preferential water and solute transport in intact soil blocks. We are quite confident that the current setup could be scaled up to accommodate considerably deeper intact soil profiles (perhaps up to 1 m) with modest strengthening of the support structures. This would permit realistic groundtruthing of various solute transport models to tile drain depths, and to further investigate the behaviour of solute transport across heterogeneous soil interlayer boundaries. The grid lysimeter system is also well suited to examine stop-and-go (intermittent) flow phenomena in soils, which may well prove to be more relevant than much of the steady-state flow experiments which have been traditionally used to characterize solute behaviour in soil profiles.

REFERENCES

1. **Altemuller, H-J. 1986.** Fluorescence light microscopy of soil/root interactions. Trans. XIII Congr. Int. Soc. Soil Sci., Hamburg p.1546-1547.
2. **Andreini, M.S. and T.S. Steenhuis. 1990.** Preferential paths of flow under conventional and conservation tillage. Geoderma 46: 85 - 102.
3. **Baker, R.S., and D. Hillel. 1990.** Laboratory tests of a theory of fingering during infiltration into layered soils. Soil Science Society of America Journal 54: 20 - 30.
4. **Baker, R.S., and D. Hillel. 1991.** Observations of fingering behavior during infiltration into layered soils. IN: Preferential Flow. Proceedings of the National Symposium, December 16 - 17, 1991; Chicago, Illinois. T.J. Gish, A. Shirmohammadi (eds). American Society of Agricultural Engineers, St. Joseph, Michigan (Publishers). pp 87 - 99.
5. **Beven, K. and P. Germann. 1982.** Macropores and water flow in soils. Water Resources Res. 18: 1311 - 1325.

6. **Bouma, J. and J.H.M. Wösten. 1979.** Flow patterns during extended saturated flow in two, undisturbed swelling clay soils with different macrostructures. Soil Science Society of America Journal 43: 16 - 22.
7. **Bouma, J., L.W. Dekker, and C.J. Muilwijk. 1981.** A field method for measuring short-circuiting in clay soils. J. Hydrology 52: 347 - 354.
8. **Buchter, B., J. Leuenberger, P.J. Wierenga, and F. Richard. 1984.** Preparation of large core samples from stony soils. Soil Sci. Soc. Amer. J. 48: 1460 - 1462.
9. **Daniels, R.E. and P.L. Sutherland. 1986.** Porosity. In "Methods of Soil Analysis, Part 1 - Physical and Mineralogical Methods", 2nd Ed. Amer. Soc. Agronomy, Soil Sci. Soc. Amer., Publ.; Madison, Wisc. Agronomy Vol. 9, Part 1, Ch.18: 443 - 461.
10. **Ehlers, W. 1975.** Observations on earthworm channels and infiltration on tilled and untilled loess soil. Soil Sci. 119: 242 - 249.
11. **Everts, C.J. and R.S. Kanwar. 1990.** Estimating preferential flow to a subsurface drain with tracers. Trans. Amer. Soc. Agr. Eng. 33: 451 - 457.

12. **Field, J.A., J.C. Parker and N.L. Powell. 1984.** Comparison of field- and laboratory-measured and predicted hydraulic properties of a soil with macropores. *Soil Sci.* 138: 385 - 396.
13. **Germann, P. and K. Beven. 1981.** Water flow in soil macro-pores. I. An experimental approach. *J. Soil Sci.* 32: 1 - 13.
14. **Kemper, W.D., T.J. Trout, A. Segeren, and M. Bullock. 1987.** Worms and water. *J. Soil Water Conservation* 42: 401 - 404.
15. **Lee, K.E. 1985.** *Earthworms, their ecology and relationship with soils and land use.* Academic Press, Orlando, Florida.
16. **Lewis, T.E., B. Blasdell, and L.J. Blume. 1990.** Collection of intact cores from a rocky desert and a glacial till soil. *Soil Sci. Soc. Amer. J.* 54: 938 - 940.
17. **Logsdon, S.D., R.R. Allmaras, L. Wu, J.B. Swan and G.W. Randall. 1990.** Macroporosity and its relation to saturated hydraulic conductivity under different tillage practices. *Soil Soc. Amer. J.* 54: 1096 - 1101.

18. **Murphey, J.B., E.H. Grissinger, and W.C. Little. 1981.** Fiberglass encasement of large, undisturbed, weakly cohesive soil samples. *Soil Sci.* 131: 130 - 134.
19. **Ogden, C.B., R. J. Wagenet, H.M. van Es and J.L. Hutson. 1992.** Quantification and modeling of macropore drainage. *Geoderma* 55: 17 - 35.
20. **Peterson, A.E. and R.M. Dixon. 1971.** Water movement in large soil pores. Res. Rep. 75: 1 - 8, Res. Div. Coll. Agr. Life Sci., Univ. of Wisc., Madison.
21. **Römken, M.J.M., L.F. Glenn, D.W. Nelson, and C.B. Roth. 1975.** A laboratory rainfall simulator for infiltration and soil detachment studies. *Soil Sci. Soc. Amer. Proc.* 39: 158-160.
22. **Selker, J.S., T.S. Steenhuis, and J.-Y. Parlange. 1991.** Wetting front instability in homogeneous sand soils under continuous infiltration. *Soil Sci. Soc. Amer. J.* 56: 1346 - 1350.
23. **Shipitalo, M.J., W.M. Edwards, W.A. Dick, and L.B. Owen. 1990.** Initial storm effects on macropore transport of surface-applied chemicals in No-Till soil. *Soil Sci. Soc. Amer. J.* 54: 1530 - 1536.

24. **Steenhuis, T.S. and J.-Y. Parlange. 1991.** Preferential flow in structured and sandy soils. IN: Preferential Flow. Proceedings of the National Symposium, December 16 - 17, 1991; Chicago, Illinois. T.J. Gish, A. Shirmohammadi (eds). American Society of Agricultural Engineers, St. Joseph, Michigan (Publishers). pp 12 - 21.

25. **Steenhuis, T.S., W. Staubitz, M.S. Andreini, J. Surface, T.L. Richard, R. Paulsen, N.B. Pickering, J.R. Hagerman and L.D. Geohring. 1990.** Preferential movement of pesticides and tracers in agricultural soils. J. Irrigation and Drainage 116: 50 - 66.

26. **Tindall, J.A., K. Hemmen, and J.F. Dowd. 1992.** An improved method for field extraction and laboratory analysis of large, intact soil cores. J. Environ. Qual. 21: 259-263.

27. **Watson, K.W. and R.J. Luxmore. 1986.** Estimating macroporosity in a forest watershed by use of tension infiltrometer. Soil Sci. Soc. Amer. J. 50: 578 - 582.

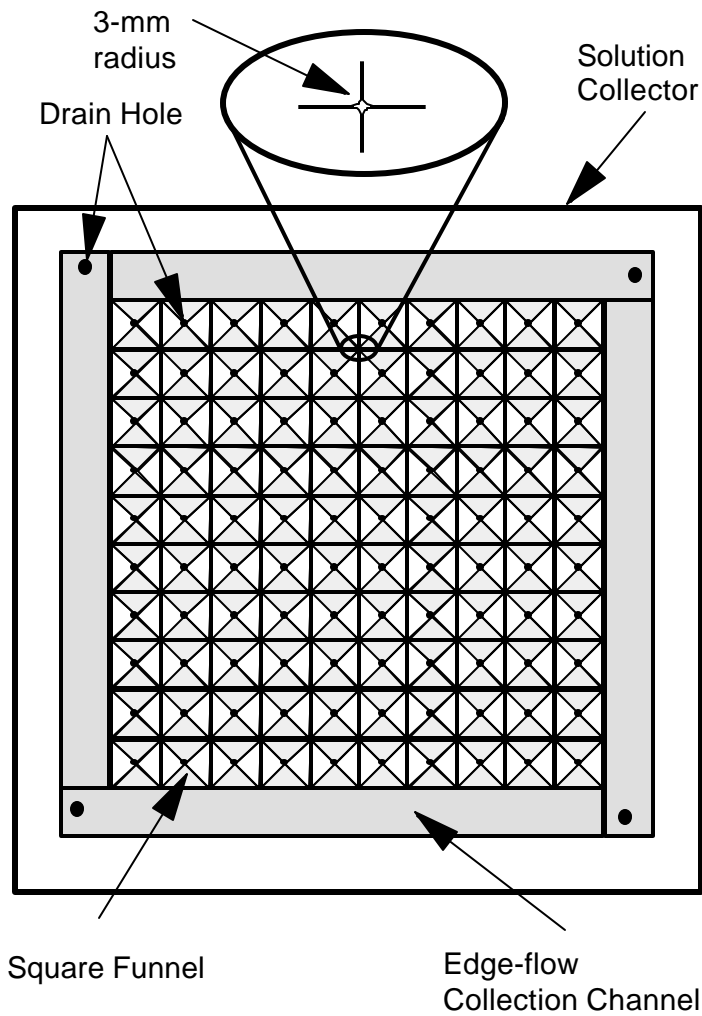

Figure 1. Solution collector with a 10 x 10 grid of 3.8-cm square funnels 1.3 cm deep, and with outer edge-flow collection channels for obtaining water and solute balance information.

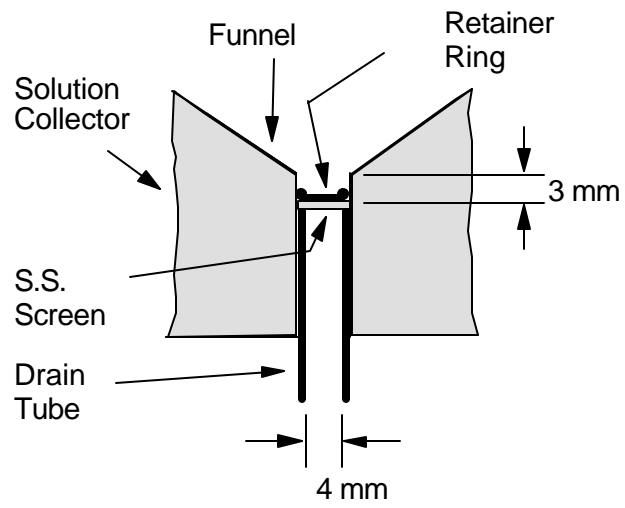

Figure 2. Schematic representation of a single funnel with drain tube assembly.
S.S.= stainless steel.

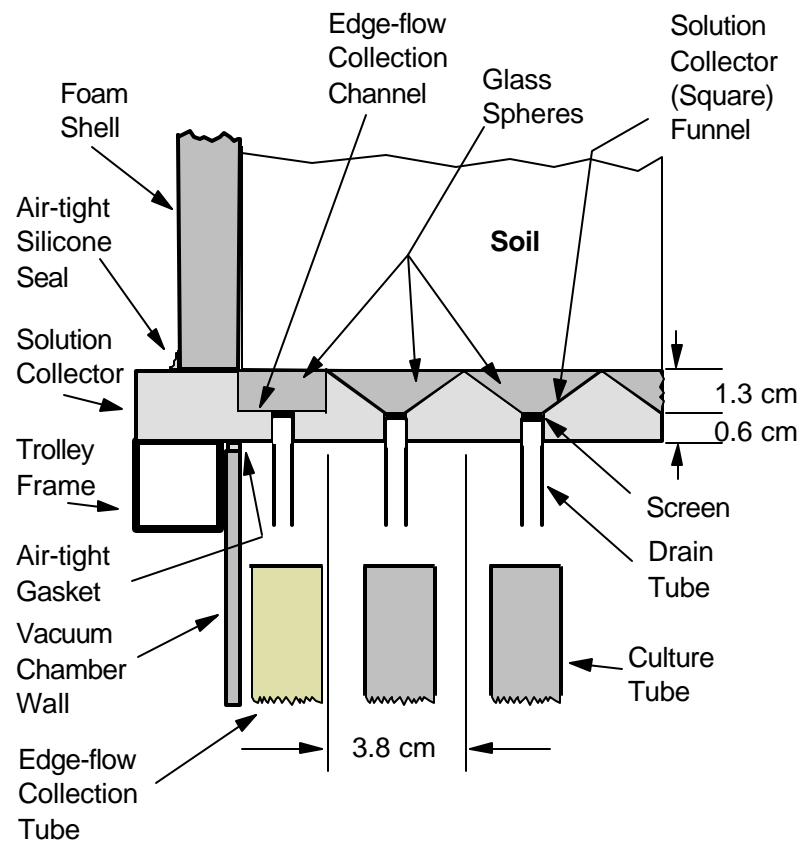

Figure 3. Detailed schematic of the mounted solution collector and vacuum chamber.

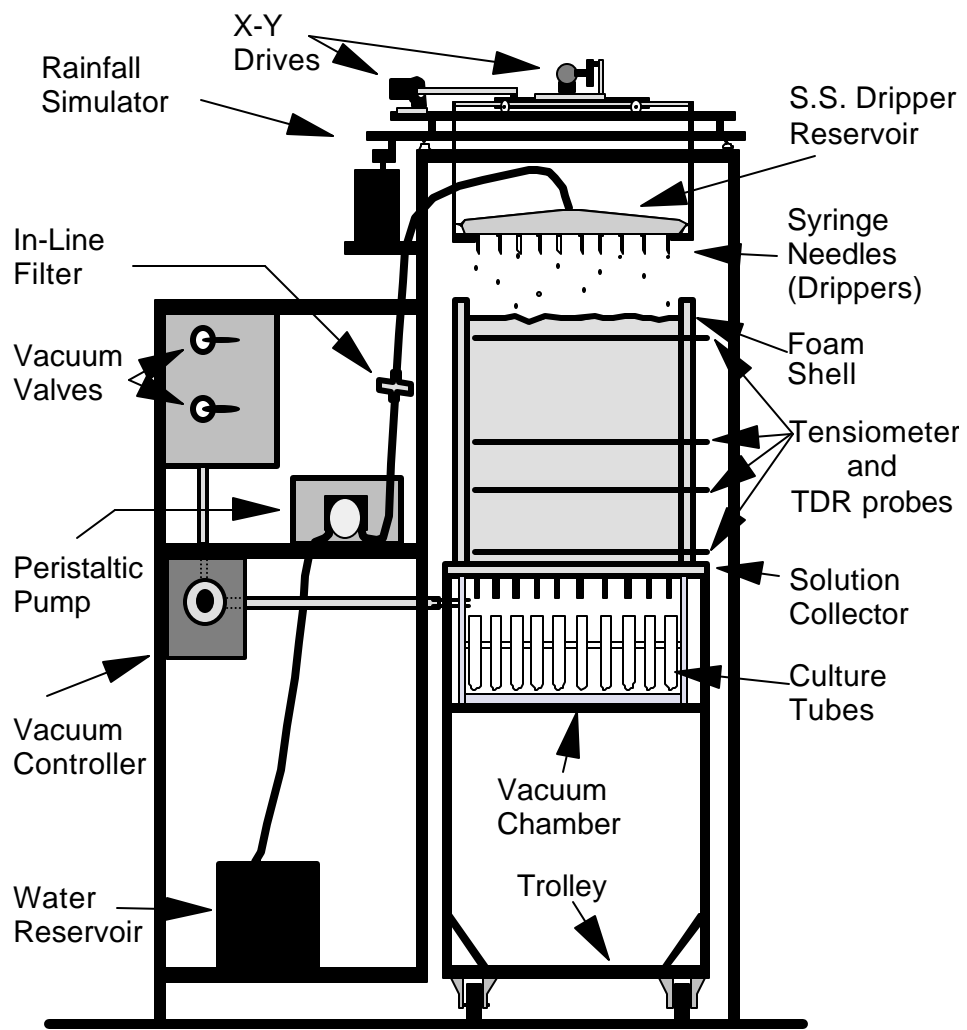

Figure 4. Schematic of the soil block positioned within the solution delivery-collection-monitoring system.

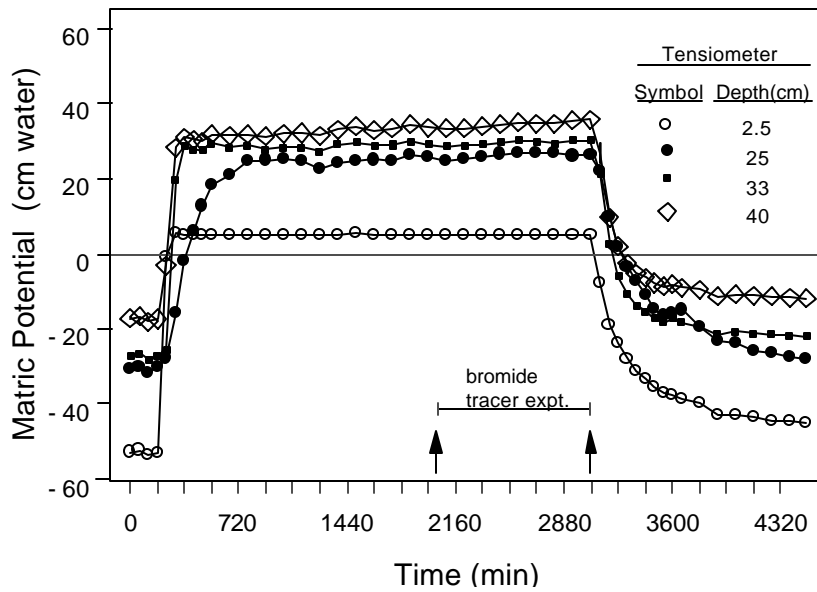

Figure 5. Response of tensiometers to a constant simulated rainfall of 19.2 mm hr⁻¹ on saturated intact soil block. Quasi-steady state, saturated flow within the block occurred after 2000 min.

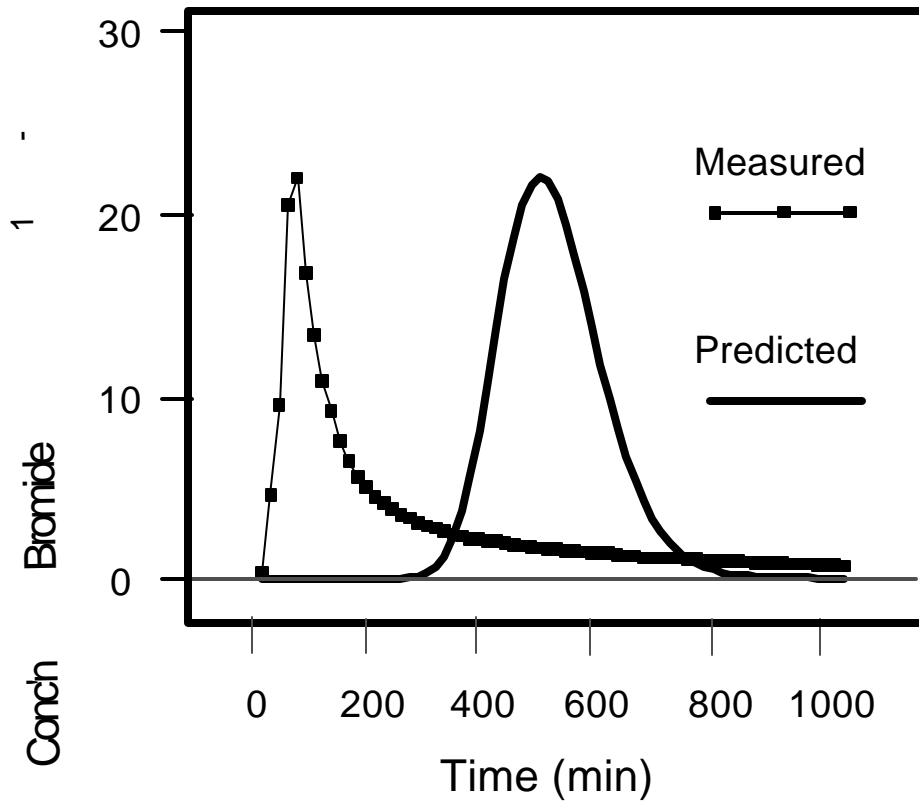

Figure 6. Comparison of measured and predicted bromide breakthrough curves (BTC) resulting from the addition of a square wave pulse (275 mL) of KBr tracer ($C_0 = 1031 \text{ mg L}^{-1}$). The $t = 0$ time corresponds to $t = 2040 \text{ min}$ in Figure 5. Input application rate = 19.2 mm hr^{-1} .

L

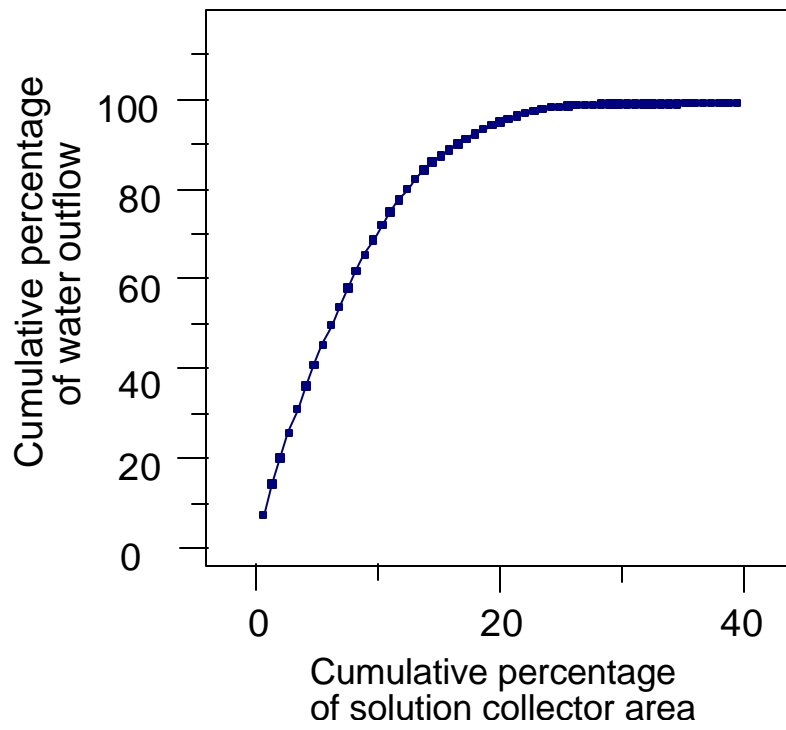

Figure 7. Distribution of water flow within the solution collector for the quasi-steady saturated flow conditions of Figure 5.

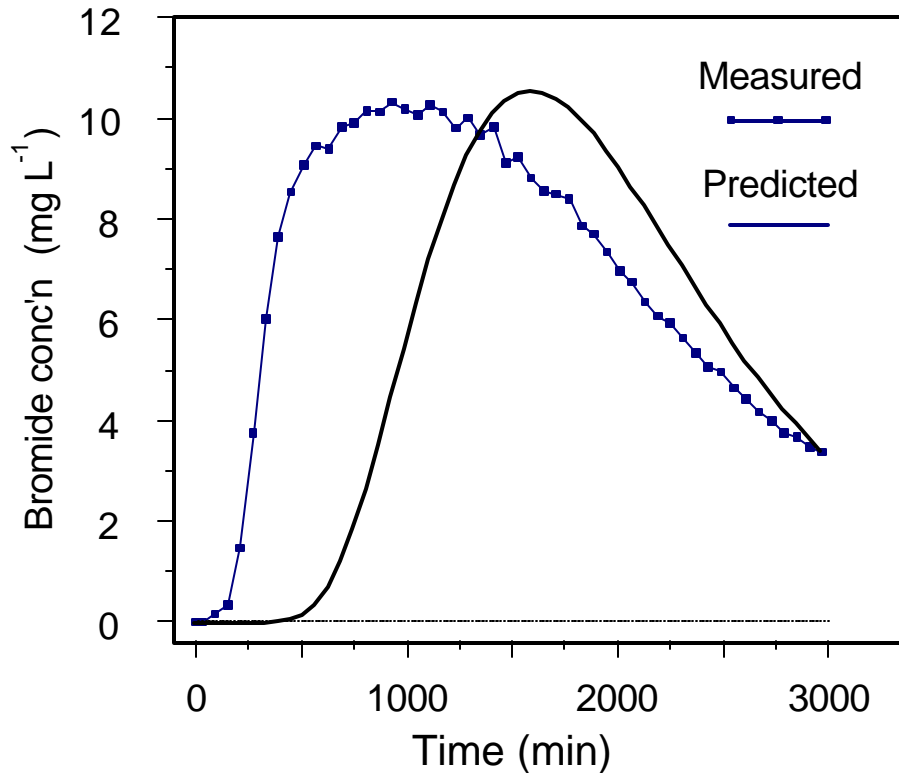

Figure 8. Comparison of measured and predicted bromide breakthrough curves (BTC) resulting from the addition of a square wave pulse (275 mL) of KBr tracer ($C_0 = 1031 \text{ mg L}^{-1}$). Input application rate = 5.6 mm hr^{-1} .

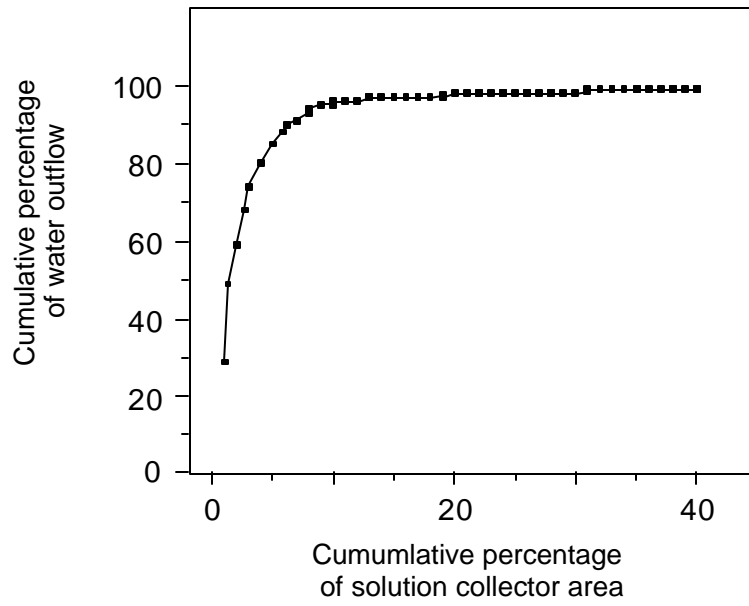

Figure 9. Distribution of water flow within the solution collector for the quasi-steady saturated flow conditions of Figure 8.