

## **MEASURING GREENHOUSE GAS EMISSIONS IN A CONTROLLED ENVIRONMENT DAIRY BARN**

by

H.A. Jackson<sup>1</sup>, R.G. Kinsman<sup>1</sup>, D.I. Massé<sup>1</sup>, J.A. Munroe<sup>1</sup>, F.D. Sauer<sup>1</sup>, N.K. Patni<sup>1</sup>, D.J. Buckley<sup>1</sup>, E. Pattey<sup>2</sup>, R. Desjardins<sup>2</sup>, M.S. Wolynetz<sup>3</sup>

- <sup>1</sup> Centre for Food and Animal Research, Research Branch, Agriculture and Agri-Food Canada, Ottawa, Ontario, Canada, K1A 0C6.
- <sup>2</sup> Centre for Land and Biological Resources Research, Research Branch, Agriculture and Agri-Food Canada, Ottawa, Ontario, Canada, K1A 0C6.
- <sup>3</sup> Western Region, Research Branch, Agriculture and Agri-Food Canada, Ottawa, Ontario, Canada, K1A 0C6.

Written for Presentation at the  
1993 ASAE International Winter Meeting  
Sponsored by  
ASAE

Hyatt Regency Hotel  
Chicago, Illinois  
December 14-17, 1993

### **Summary:**

This paper describes a monitoring system developed to continuously measure, on a 30 minute basis, greenhouse gas (methane and carbon dioxide) emissions from a 118 cow controlled environment dairy barn. Results obtained over an eight month period are presented.

### **Keywords:**

carbon dioxide, methane, emission, global warming, animal manure, rumen, controlled environment, air flow rate, dairy barn, dairy cattle, milking cows, data acquisition, control system

The author(s) is solely responsible for the content of this technical presentation. The technical presentation does not necessarily reflect the official position of ASAE, and its printing and distribution does not constitute an endorsement of views which may be expressed.

Technical presentations are not subject to the formal peer review process by ASAE editorial committees; therefore, they are not to be presented as refereed publications.

Quotation from this work should state that it is from a presentation made by (name of author) at the (listed) ASAE meeting.

EXAMPLE - From Author's Last Name, Initials. "Title of Presentation." Presented at the Date and Title of meeting, Paper No. X. ASAE, 2950 Niles Rd., St. Joseph, MI 49085-9659 USA.

For information about securing permission to reprint or reproduce a technical **presentation**, please address inquiries to ASAE.

## INTRODUCTION

Greenhouse gases (carbon dioxide, methane and nitrous oxide) accumulate in the atmosphere and contribute to global warming. It is estimated that farm animals are responsible for 15 to 25 per cent of total global man-made emissions of methane (USEPA, 1990). Cattle account for about 70 per cent of the emissions attributed to farm animals.

There is, however, a great deal of debate concerning the reliability of these estimates. A major problem has been the manner in which these estimates have been made. Single animals were placed in special sealed chambers and the gas emissions measured. This method, while providing valuable information on gas emissions from cattle, leaves room for significant error. Placing animals in chambers exposes them to additional stress and limits the ability to integrate the variability between animals, both of which can bias results.

This paper describes a system developed for measuring greenhouse gas emissions (methane and carbon dioxide) from a 118 cow controlled environment dairy barn and presents preliminary results on gas emission rates. A review of the literature on methane emissions from the rumen and from animal manure is included in this paper.

## REVIEW OF THE LITERATURE

Accumulation of methane and carbon dioxide in the atmosphere is contributing to the greenhouse effect. Carbon dioxide is expected to account for 55% of future temperature increases while methane should account for 15% (Rosswall, 1991). Human activities that have contributed to the increase of greenhouse gases in the atmosphere include flooded rice cultivation, coal mining, oil and gas production and distribution, biomass burning, slash and burn land clearing, landfills, sewage handling, proliferation of domestic ruminant animals and their waste, and livestock waste management systems (USEPA, 1990).

Several authors have estimated total global emissions of methane from all sources including emissions from livestock and livestock wastes (Table 1). The USEPA (1990) acknowledged that the magnitude of these estimates is reasonable but suggested that there are large uncertainties in current estimates.

Farm animals in Canada are contributing a small share of total global emissions. Jaques (1992) estimated methane emissions from ruminant livestock in Canada to be 0.85 Tg/year. Casada and Safley (1990) calculated methane emissions from manure in Canada to be 0.33 Tg/year. The total methane emissions from livestock and livestock manure in Canada would then be less than 1% of current estimates of global methane emissions from livestock and livestock manure.

### **Methane Production From the Rumen**

Methane is a by-product of the fermentation process of ruminating animals and represents a loss in feed conversion efficiency. Methane production rate is dependant on several factors including energy intake, enteric ecology, energy expenditure of the animal, quantity and quality of feed, body weight, and age (Jaques, 1992). Typically, from 4 to 9% of gross energy intake is lost through methane production. The mechanisms of methane production in the rumen have been reported extensively. However, there is little information available for modelling methane production from cattle (Kirchgessner et al., 1991). Sauer and Teather (1987) showed that ionophores widely used with beef cattle significantly reduce methane production in the rumen. Sauer et al. (1989) also showed that these ionophores could be used successfully with dairy cattle.

Methane production, as it relates to feed conversion efficiency, has been reported extensively in the literature (Table 2). The published data have been obtained using small numbers of cattle isolated in environmental control chambers located in North America and Europe. There is little information available on greenhouse gas emissions from large groups of cattle in working dairy barns.

Although the published data on methane emissions from dairy cattle vary widely (96 to 615 L/cow/ day), it is generally agreed that variation in methane emissions from dairy cattle can be explained by differences in diet, milk yield, and metabolic live weight. Kirchgessner et al. (1991) is the only author to model methane emissions using these parameters.

There is a diurnal pattern to methane production from cattle. Muller et al. (1980), Moe et al. (1973a,b) and Whitelaw et al. (1984) reported an increase of 10 to 100 percent after each feeding, a consistent reduction between feedings, and a decline in emissions overnight. Muller et al. (1980) found that the magnitude of this increase depends on the number of times concentrate was fed throughout the day. Moe et al. (1973a,b) showed that, although diet influenced the quantity of methane produced, it did not have an effect on diurnal patterns of methane production.

Carbon dioxide is exhaled from the lungs and is also produced in the rumen fermentation process. Table 3 contains a summary of the data in the literature on carbon dioxide emissions from dairy cattle. Carbon dioxide emission has been studied mainly as an indicator of air quality in barns.

### **Greenhouse gas concentration in farm animal enclosures**

Some authors have measured greenhouse gas concentration in dairy barns as an indication of air quality. Skarp (1975) performed comprehensive measurements of the vertical distribution of manure gases in Swedish livestock buildings with both solid and liquid manure handling systems. The results of this study indicated that (i) ambient methane concentration of exhaust air ranged from about 50 ppm to almost 250 ppm in a cattle barn depending on ventilation rate and time of day, (ii) in cattle barns with liquid manure systems, the winter methane concentrations ranged from 150 ppm near the ceiling to 50 ppm near the floor, and (iii) methane concentration is higher in barns where the manure is removed once a week than in barns where manure is removed twice a day.

Clark and McQuitty (1987) monitored six Alberta commercial free-stall dairy barns from December to March and found that the average ambient carbon dioxide concentration ranged from 1727 to 3553 ppm, with a peak hourly mean concentration of 5747 ppm. Feddes et al. (1984) observed a mean concentration of 2300 to 2400 ppm in three dairy barns and 4040 ppm in another, from January to March. Skarp (1975) measured carbon dioxide in a cattle barn during the winter and found carbon dioxide to vary from about 1500 to 3500 ppm depending on the time of day. Other measurements showed that carbon dioxide in cattle barns with liquid manure systems ranged from 1000 ppm to 3500 ppm depending on ventilation rate. Vertical distribution of carbon dioxide was about 2800 ppm close to the ceiling and 1450 ppm 10 cm above the floor.

### **Methane production from manure**

Methane and carbon dioxide are primary decomposition products of anaerobic decomposition of organic material. The quantity of methane and carbon dioxide produced from animal waste depends on species, ration, age of the animal, collection and storage method, temperature, and the amount of foreign material (i.e. bedding) incorporated into the waste (Chen, 1983). The waste management system determines the proportion of waste that is anaerobically digested and the yield of methane and carbon dioxide. Liquid and slurry systems typically cause anaerobic conditions to develop whereas waste in solid systems and deposited in pastures tends to dry out and aerobic conditions predominate (Casada and Safley, 1990). Patni and Jui (1985, 1987) found that about 25% of the carbon initially

present in dairy cattle manure slurry stored in farm tanks in Eastern Ontario was presumably lost in the gas emanating from the slurry during 5 to 9 months of storage. This indicated that stored manure slurry can be a substantial contributor to gas emissions from animal operations.

Optimizing methane production from dairy manure in anaerobic digesters has been reported extensively in the literature (Table 4). Very little data are available relating methane production and recovery to other manure management systems. It is generally agreed that hydraulic retention time, diet, and temperature influence methane production rate in anaerobic digesters. These data (Table 4) are not directly applicable to other types of waste management systems because animal waste is seldom at temperatures of 35°C to 60°C.

Average methane production from swine manure at 20°C in lab scale anaerobic digesters was 0.0075 to 0.015 m<sup>3</sup>/kgVS/day over a 60 day period (Massé et al., 1993). This is considerably less than indicated in the literature (Table 4).

## **MATERIALS AND METHODS**

### **Facility**

The west wing of a 118 cow tie stall dairy barn at the Centre for Food and Animal Research, Agriculture and Agri-Food Canada Greenbelt Research Farm in Ottawa, Ontario, Canada was used for this study. A floor plan and section of this barn are shown in Figure 1. The west wing is 20.4 m wide by 40.8 m long with a capacity for 118 lactating cows; it is directly connected to a 30-cow capacity pre-milking holding area and a double-8 herringbone milking parlour.

The negative pressure ventilation system for the west wing consists of 15 thermostat-controlled exhaust fans (four 30.5 cm 2-speed, six 76 cm single speed and five 91.5 cm single speed) protected by weather hoods, 39 m of self-adjusting ceiling-mounted centre air inlets and a 39 m long centre recirculation duct with two 51 cm variable speed fans. For summer peak heat loads, 8 manually controlled centre slide inlets (400 mm wide by 1200 mm long) can be opened.

The manure handling system for the west wing consists of two gutter cleaners that transfer the manure/bedding mixture via discharge openings into an under-floor liquid manure tank for two to three week storage. A tractor-powered chopper-equipped manure pump agitates, mixes and pumps the liquid manure into tankers for transfer to large remote liquid manure tanks for long term storage (6 months or more).

### **Gas emission monitoring system**

The procedure used to determine carbon dioxide and methane emissions from the dairy cows involves continuously measuring gas concentrations of incoming and exhausted ventilation air and the air flow rate through the building envelope and then calculating the emission rates.

The gas emission monitoring system consists of (i) a gas sampling system (ii) a data acquisition and control system and (iii) an air flow measurement system.

The multipoint (24 points) gas sampling system, consisting of two 12-port Samplivalves (Scanivalve Corp. model S65 1P-12T), two 3-way valves (Parker Hannifin Corp. model 04F30U2111A3FGC75 12-Volt dc), an exhaust pump (Gast model LAAV110GB vacuum pump with a capacity of 445 L/min at 0 mm Hg) and a sample pump (Neuberger model N10KN1 vacuum pump with a capacity of 13.3 L/min at 0 mm Hg), selects and delivers air samples to a Siemens Ultramat 5E autoranging infrared methane gas analyzer (with ranges of 0-100, 0-200, 0-500 and 0-1000 ppm with a repeatability equal to or less

than 1%) and a Siemens Ultramat 21 infrared carbon dioxide analyzer (with a range of 0 to 5000 ppm with a repeatability of less than 1% of reading). Figure 2 shows a schematic of the gas sampling and data acquisition and control system.

The gas sampling locations and the location of the monitoring equipment room are shown in Figure 3. Gas is continuously drawn from the exhaust fan hoods of each of the 15 exhaust fans (SE 76, SE 30.5, SE 91.5, S 76, S 91.5, SW 91.5, SW 30.5, SW 76, NW 76, NW 30.5, NW 91.5, N 76, NE 91.5, NE 30.5, NE 76), from the air plenum supplying fresh air to the centre inlets (OD), from the wind sensor tower (WT), from each of two gutter cleaner discharge openings into the attached manure tank (MTS, MTN) and from five locations within the barn (CSE, CS, CSW, CNW, CN, CNE). The Samplivalves and 3 way valves sequentially select each location for 1 minute (1.5 minutes where large differences in sample concentration are expected) and repeat the complete cycle every 30 minutes. The sampling pump delivers the selected gas sample to the gas analyzers at about 3.5 L/min. The exhaust pump continuously draws about 3.5 L/min of air from each of the other 23 gas sampling lines.

To minimize contamination of the gas sampling lines and the analyzers from moisture, dust and airborne particles, a condensate and 5 micron particulate filter was installed near the inlet of each of the gas sampling lines. A condensate and fine dust filter was also installed in the gas line leading to each analyzer. A Mak2-1 sample gas conditioner was also installed in this gas line to remove water vapour.

To ensure that the measured gas concentration from the 15 fans and the fresh air plenum is representative of the gas concentration at these locations for the 30 minute sampling period, a gas averaging reservoir (30.5 cm diameter by 137 cm long pvc pipe with plexiglas ends) was recently installed in these sampling lines. Inside the pvc pipe is a sealed polyethylene film tube (poly tube) of the same dimensions. Two 3-way solenoid valves (Parker Hannifin Corp. model 04F30U2111A3FGC75 12-Volt dc) at each reservoir direct the continuously flowing gas sample to fill the cavity inside each poly tube while at the same time evacuating the cavity between the poly tube and the pvc pipe for the 30 minute sampling period. At the end of each 30 minute sampling period, the control software activates the 3-way valves and reverses the procedure, emptying the poly tube and filling the cavity between the poly tube and the pvc pipe. The data presented in this paper were collected prior to the installation of the gas averaging reservoirs.

The data acquisition and control system consists of a Sciometric Instruments model 200 data acquisition and control system connected to an IBM AT compatible computer running two software programs simultaneously (i) Copilot, a data acquisition and control program running in the foreground, and (ii) Close-up, a remote communications program running in the background and configured for dial-back security protection. The data acquisition and control system records the gas concentration for each sampling location at the end of the sampling period, controls the two Samplivalves and the two 3-way valves as well as all of the 3-way valves on the gas sample averaging reservoirs. The data acquisition and control system can be remotely accessed from any IBM compatible computer with a modem.

The air flow measurement system consists of D.J. Instruments model LPTV-005-C-2 pressure transducers with a range of 0-13 mm water gauge installed at each of the six fan banks, and Sprague/Allegro model VGN3113V hall effect transducers mounted on each of the 15 ventilation fans (Figure 3). The pressure transducers measure the static pressure drop across the building envelope and the hall effect transducers measure fan RPM. The measured data was used to calculate the airflow rate through each fan on a continuous basis from previously determined calibration curves for each fan. The fan calibration curves were determined using portable fan calibration ducts that were temporarily installed on the inlet side of each fan. Figure 4 shows a fan calibration duct for the 76 cm fans. The design of the fan calibration ducts and the fan calibration procedure are similar to AMCA (1990). A

throttling device was used to vary fan static pressure. An inlet bell and a flow straightener conforming to AMCA (1986) were added to minimize air flow turbulence.

## RESULTS AND DISCUSSION

Greenhouse gas emissions have been monitored continuously since April 4, 1993 (Figure 5). The average daily emission rate of methane for the April to November, 1993 period was  $542 \pm 83$  L/cow/day. This is near the high end of the range of emissions reported in the literature (Table 2). The average daily emission rate of carbon dioxide over the same period was  $5867 \pm 825$  L/cow/day which is also near the high end of the range of values reported in the literature (Table 3).

There were some variations in calculated daily emission rates throughout the monitoring period. Normal changes in management practices may explain the large variations in April, June, and October. In April the feeding regime was altered, in June the bedding was changed from shavings to straw, and in October there were diet changes. Also, the number of cows, herd composition, and the proportion of non-lactating cows changed. Kirchgessner et al. (1991) and Muller et al. (1980) showed that non-lactating cows produce considerably less methane than lactating cows. Changes in dairy herd management are unavoidable in a working dairy barn over long periods of time, however, treatment evaluation periods should be limited to times where herd composition, diet and other parameters can be held reasonably constant.

A definite diurnal emission pattern was observed (Figure 6). Emission rate increased rapidly after each feeding and slowly declined between feedings and at night. This is very similar to the diurnal patterns reported by Muller et al. (1980), Moe et al. (1973a,b) and Whitelaw et al. (1984). Normal changes in daily management routine and activity in the barn resulted in higher variability in emission rates during the day time.

Each of the 15 fans was calibrated at least twice. Figure 7 shows a series of calibration curves for the southwest 30.5 cm two-speed fan. All of the calibration curves were linear in the range of pressures normally encountered in this barn. Differences in calibration curves between fan calibration dates are probably due to the poor location of the outdoor static pressure reference prior to June 22, 1993. Outdoor static pressure reference was located high on the wind sensor tower where it may have been influenced by wind velocity pressure. In May of 1993 outdoor static pressure references were installed on the outside wall beside each fan and were shielded from wind velocity pressure.

The details of systems to measure the gas emissions from animal manure in a full-scale liquid manure tank and from lab-scale manure storages will be described in other papers at a later date. Also, the development and evaluation of techniques to reduce methane emissions from the rumen and animal manure will also be presented at a later date.

## **CONCLUSIONS**

Monitoring greenhouse gas emissions from a large number of animals in a working dairy barn is feasible and yields results of the same order of magnitude to those reported in the literature for animals isolated in environmental chambers. The average daily emission rates of methane and carbon dioxide over an 8 month period were 542 L/cow/day and 5867 L/cow/day respectively. A definite diurnal pattern of gas emissions was observed which was very similar to patterns reported in the literature.

Consequently, it appears feasible to evaluate the effectiveness of techniques for reducing methane and carbon dioxide emissions using a large number of cattle in a working dairy barn. However, daily management routines, such as milking and feeding and other parameters such as ration formulation and animal numbers, all contribute to variations which must be taken into consideration before interpreting the effectiveness of various treatments to reduce methane and carbon dioxide emissions.

## **ACKNOWLEDGEMENTS**

The authors would like to acknowledge the contributions from the following: A. Olson and M. Lemieux in installing the gas measuring system; R. Pella for assistance with the illustrations; M. Marengère, S. Sattlecker, A. McGrath, C. Booth and A. Saumure for their assistance in the design and fabrication of some of the specialized research equipment; G. St-Amour and M. Lefebvre for electronics expertise; P. Plue, J. Achtereekte, J. Moffat and S. Campbell for their assistance in upgrading the barn; R. Perron, D. Featherston and barn staff for their cooperation in managing the animals; B. Starr and the manure handling crew for cooperation in emptying the manure tank; T. Shea, J. Wyss and C. Dickinson for their assistance in procuring the research materials and equipment; Drs. S.K. Ho, V. Stevens and A. Lachance for their support in the conduct of this project; other CFAR staff who assisted with this project; and Sciometric Instruments for their input in developing the multipoint gas sampling system.

## REFERENCES

- AMCA. 1990. Field performance measurement of fan systems. AMCA Publication 203-90. Air Movement and Control Association, Inc., Arlington Heights, IL.
- AMCA. 1986. American national standard laboratory methods of testing fans for rating. ANSI/AMCA Standard 210-85. ANSI/ASHRAE Standard 51-1985. Air Movement and Control Association, Inc., Arlington Heights, IL.
- Casada, M.E. and L.M. Safley Jr. 1990. Global methane emissions from livestock and poultry manure. A report submitted to the U.S.E.P.A. Washington, D.C.
- Chen, T.H., D.L. Day and M.P. Steinberg. 1988. Methane production from fresh versus dry dairy manure. *Biological Wastes*. 24:297-306
- Chen, Y.R. 1983. Kinetic analysis of anaerobic digestion of pig manure and its design applications. *Agricultural Wastes*. 8:65-81.
- Cicerone, M.E. and R.S. Oremland. 1988. Biogeochemical aspects of atmospheric methane. *Global Biogeochemical Cycles*. 2(4):299-327.
- Clark, P.C. and J.B. McQuitty. 1987. Air quality in six Alberta commercial free-stall dairy barns. *Canadian Agricultural Engineering*. 29(1):77-80.
- Converse, J.C., R.E. Graves and G.W. Evans. 1977. Anaerobic degradation of dairy manure under mesophilic and thermophilic temperatures. *Transactions of the ASAE* 20(2):336-340.
- Crutzen, P.J. 1991. Methane sinks and sources. *Nature*, 350:380-381.
- Crutzen, P.J., I. Aselmann and W. Seiler. 1986. Methane production by domestic animals, wild ruminants, other herbivorous fauna, and humans. *Tellus*. 38B:271-284.
- Ehhalt, D.H. 1974. The atmospheric cycle of methane. *Tellus*. 26:58-70.
- Feddes, J.J.R., J.J. Leonard and J.B. McQuitty. 1984. Carbon dioxide concentration as a measure of air exchange in animal housing. *Canadian Agricultural Engineering*. 26(1):53-56.
- Flatt et al., 1969. Cited in Kirchgessner, 1991.
- Hoffmann, L., W. Jentsch, H. Wittenburg, and R. Schiemann. 1972. Utilization of food energy for milk production (In German). *Arch. Tierernahrung*. 22(10):721-742.
- Jaques, A.P. 1992. Canada's greenhouse gas emissions: estimates for 1990. Report EPS 5/AP/4. Environmental Protection Publications, Environment Canada, Ottawa, Ontario, Canada, K1A 0H3.
- Jentsch, W., H. Wittenburg and R. Schiemann. 1972. Utilization of food energy for milk production, (4) studies on the degree of food energy utilization with the use of rape seed oil (In German). *Arch. Tierernahrung*. 22(10):607-720.
- Jewell et al., 1979. Cited in Hill, D.T. 1984. Methane productivity of the major animal waste types. *Transactions of the ASAE*. 27:530-434.

- Kirchgessner, M., W. Windisch, H.L. Muller and M. Kreuzer. 1991. Release of methane and of carbon dioxide by dairy cattle. *Agribiol. Res.* 44, 2-3.
- Kruezer, V.M. and M. Kirchgessner. 1985. Feed intake and nutrient digestibility of cows during and after feeding protein in excess. Part 1. The influence of incorrect protein nutrition of lactating cows and its consequences. *Z. Tierphysiol., Tierernahag., u. Futtermittelkde.* 53:170-185.
- Lerner, J.E., E. Matthews and I. Fung. 1988. Methane emissions from animals: a global high-resolution data-base. *Global Biogeochemical Cycles.* 2(2):139-156.
- Lo, K.V., N.R. Bulley and P.H. Liao. 1984. Biogas production from dairy manure and its filtrate. *Canadian Agricultural Engineering.* 25(1):59-61.
- Lo, K.V., P.H. Liao, N.R. Bulley and S.T. Chieng. 1984. A comparison of biogas production from dairy manure filtrate using conventional and fixed-film reactors. *Canadian Agricultural Engineering.* 26(1):73-78.
- Massé, D.I., R.L. Droste, K. Kennedy and N.K. Patni. 1993. Psychrophilic anaerobic treatment of swine manure in intermittently fed sequencing batch reactors. *Amer. Soc. of Agric. Eng. Paper no. 93-4569, St. Joseph, MI, 49085.*
- Moe, P.W. and H.F. Tyrrell. 1979. Methane production in dairy cows. *Journal of Dairy Science.* 62:1583-1586.
- Moe, P.W., H.F. Tyrrell and N.W. Hooven. 1973a. Physical form and energy value of corn grain. *J. Dairy Sci.* 56(10): 1298-1305.
- Moe, P.W., H.F. Tyrrell and N.W. Hooven. 1973b. Energy balance measurements with corn meal and ground oats for lactating cows. *J. Dairy Sci.* 56(9):1149-1153.
- Muller, V.H.L., J. Sax and M. Kirchgessner. 1980. Influence of feeding frequency on energy losses via feces, urine and methane in nonlactating and lactating cows (In German). *Z. Tierphysiol., Tierernahag., u. Futtermittelkde.* 44:181-189.
- Patni, N.K. and P.Y. Jui. 1985. Volatile fatty acids in stored dairy cattle slurry. *Agricultural Wastes* 13: 159-178.
- Patni, N.K. and P.Y. Jui. 1987. Changes in solids and carbon content of dairy cattle slurry in farm tanks. *Biological Wastes* 20: 11-34.
- Rohrmoser, V.G., H.L. Muller and M. Kirchgessner. 1983. Energy balance and energy utilization of lactating cows under restricted protein supply and subsequent refeeding (In German). *Z. Tierphysiol., Tierernahag., u. Futtermittelkde.* 50:216-214.
- Rorick, M.B., S.L. Spahr, and M.P. Bryant. Methane production from cattle waste in laboratory reactors at 40 and 60°C after solid-liquid separation. *J. Dairy Sci.* 63:1953-1956.
- Rosswall, T. 1991. Greenhouse gases and global climate change: International collaboration. *Env. Sci. Tech.* 25(4):567-573).

- Safley, L.M. and P.W. Westerman. 1990. Psychrophilic anaerobic digestion of dairy cattle manure. In: Proceedings of the 6th International Symposium on Agricultural and Food Processing Wastes. ASAE, St. Joseph, MI, USA.
- Sauer, F.D. and R.M. Teather. 1987. Changes in oxidation reduction potentials and volatile fatty acid production by rumen bacteria when methane synthesis is inhibited. *J. Dairy Science* 70: 1835-1840.
- Sauer, F.D., J.K.G. Kramer and W.J. Cantwell. 1989. Antikeptogenic effects of monensin in early lactation. *J. Dairy Science* 72: 436-442.
- Sechen, S.J., D.E. Bauman, H.F. Tyrell and P.J. Reynolds. 1989. Effect of somatotropin on kinetics of nonestrified fatty acids and partition of energy, carbon, and nitrogen in lactating dairy cows. *J. Dairy Sci.* 72:59-67.
- Seiler, W. 1984. Contribution of biological processes to the global budget of  $\text{CH}_4$  in the atmosphere. In: M.J. Klug and C.A. Reddy (eds.). *Current Perspectives in Microbial Ecology*. American Society for Microbiology. Washington.
- Skarp, S. 1975. Manure gases and air currents in livestock housing. In: Proceedings; 3rd International Symposium on Livestock Wastes. ASAE, St. Joseph, MI, USA.
- Tyrell, H.F. et al. 1988. Cited in Kirchgessner et al., 1991.
- U.S.E.P.A. 1990. Methane emissions and opportunities for control. U.S.E.P.A., Washington, D.C.
- Whitelaw, F.G., J.M. Eadie and L.A. Bruce. 1984. Methane formation in faunated and ciliate-free cattle and its relationship with rumen volatile fatty acid proportions. *Br. J. Nutr.* 52:261-275.

**Table 1. Estimates of annual methane emissions from livestock, livestock**

Source	Livestock (Tg/year)	Livestock wastes (Tg/year)	Total global emissions
Crutzen, 1991	80		505 ± 105
Casada and Safley, 1990		28.4	
Cicerone and Oremland, 1988	65 - 100	35	440 - 640
Lerner et al., 1988	75.8		
Crutzen et al., 1986	71		
Seiler, 1984	72 - 99		225 - 395
Ehhalt, 1974	101		545 - 1035

<sup>1</sup> Tg = 1x10<sup>12</sup> gm = 1x10<sup>6</sup> tonnes

**Table 2. Published daily methane emission rates from dairy cattle.**

Methane (CH <sub>4</sub> ) Emissions (L/cow/day)		Reference
Average	Range	
453	345 - 630	Kirchgessner et al., 1991
557		Sechen et al., 1989
468		Tyrell et al., 1988
	365 - 428	Kruezer et al., 1985
	329 - 368	Rohrmoser et al., 1983
	360 - 390	Muller et al., 1980
346	96 - 615	Moe and Tyrrell, 1979
	266 - 280	Moe et al., 1973a
	303 - 389	Moe et al., 1973b
	336 - 553	Jentsch et al., 1972
444	318 - 614	Hoffman et al., 1972
296		Flatt et al., 1969
	248 - 263**	Muller et al., 1980
302**		Kirchgessner et al., 1991

\*\* not lactating

**Table 3. Published carbon dioxide emission rates from dairy cattle.**

Carbon Dioxide (CO <sub>2</sub> )	Emissions	Reference
Average	Range	
4906		Kirchgessner et al., 1991
5362		Tyrell et al., 1988
6515		Sechen et al., 1989
	2280 - 14088**	Clark and McQuitty, 1987
	4344 - 7632	Feddes et al., 1984

\*\* Based on peak one hour monitoring period (587 L/cow/hour)

**Table 4. Published data for methane production**

Temperature (°C)	Hydraulic retention time (days)	Methane yield Gas (m <sup>3</sup> /kgVS/day)	Quality (%CH <sub>4</sub> )	Reference
35	1	0.11	66	Lo et al., 1984
35	3	0.12	66	Lo et al., 1984
35	4	0.13	64	Lo et al., 1984
35	6	0.16	64	Lo et al., 1984
35	8	0.2	68	Lo et al., 1984
35	10	0.20-0.23	40	Converse et al., 1977
35	12	0.31	68	Lo et al., 1984
35	15	0.28-0.31	53	Converse et al., 1977
35	16	0.29	68	Lo et al., 1984
35	30	0.22	--	Jewell et al., 1979
35	66	0.34	70	Safley and Westerman, 1990
37	120	0.04-0.10	--	Chen et al., 1988
40	3	0.17	--	Rorick et al., 1980
40	5	0.24	--	Rorick et al., 1980
40	6	0.17	--	Rorick et al., 1980
40	10	0.16	--	Rorick et al., 1980
60	10	0.16-0.21	45	Converse et al., 1977
60	15	0.21-0.22	48	Converse et al., 1977

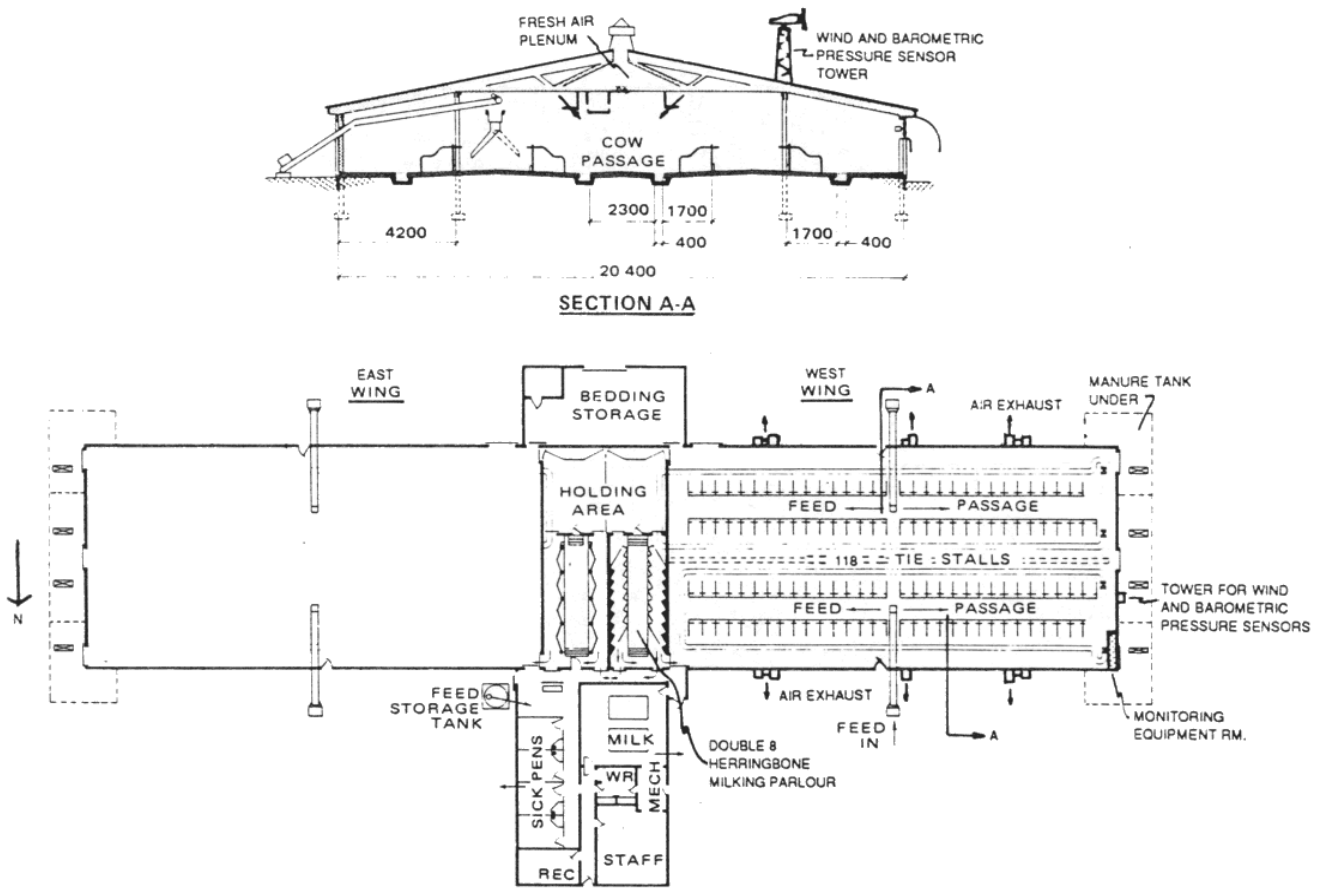

Figure 1. Floor plan and section of dairy barn used for this study

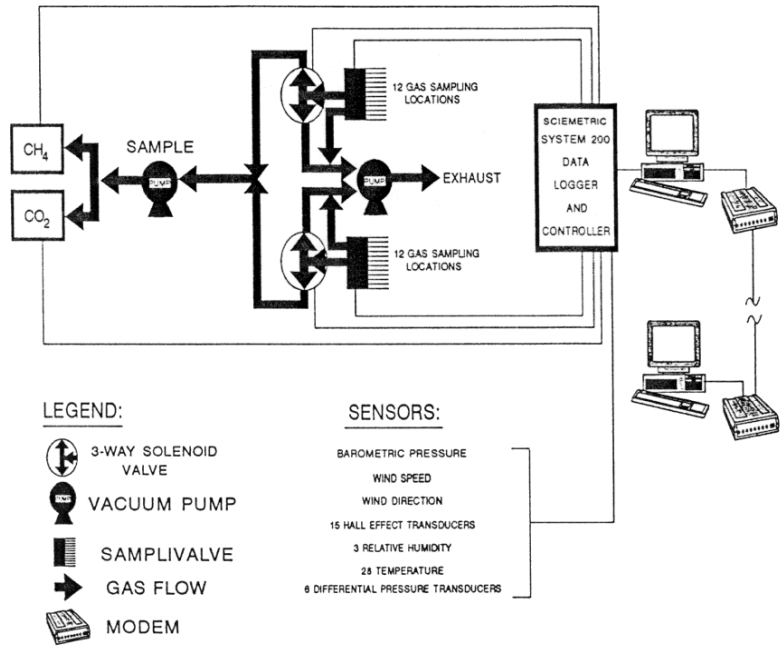

Figure 2. Gas sampling system and data acquisition and control system

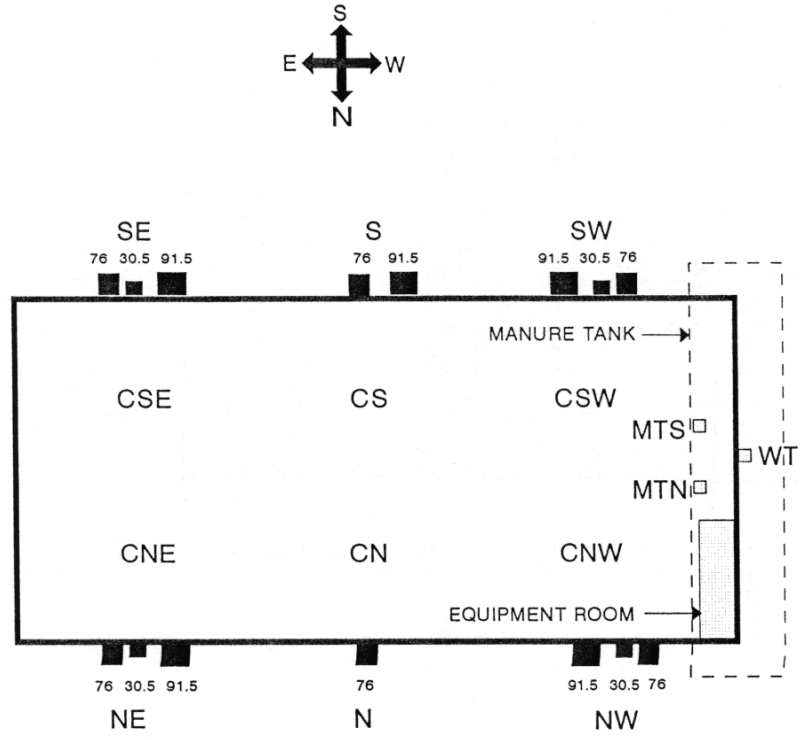

Figure 3. Gas sampling locations in the barn

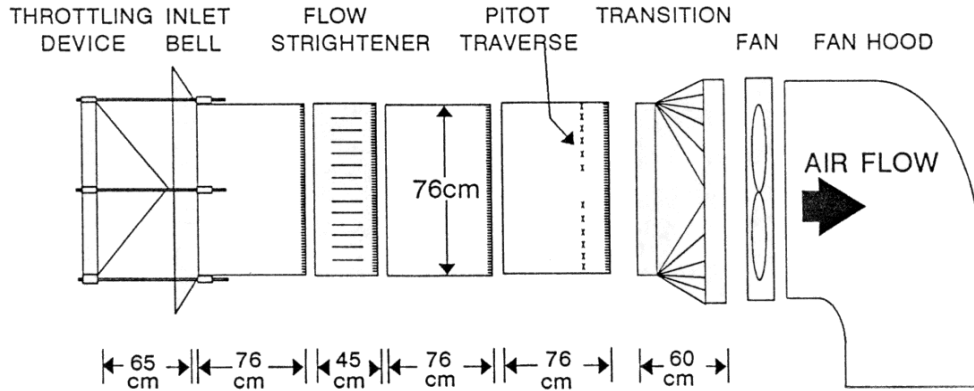

Figure 4. Fan calibration duct for the 76 cm fans

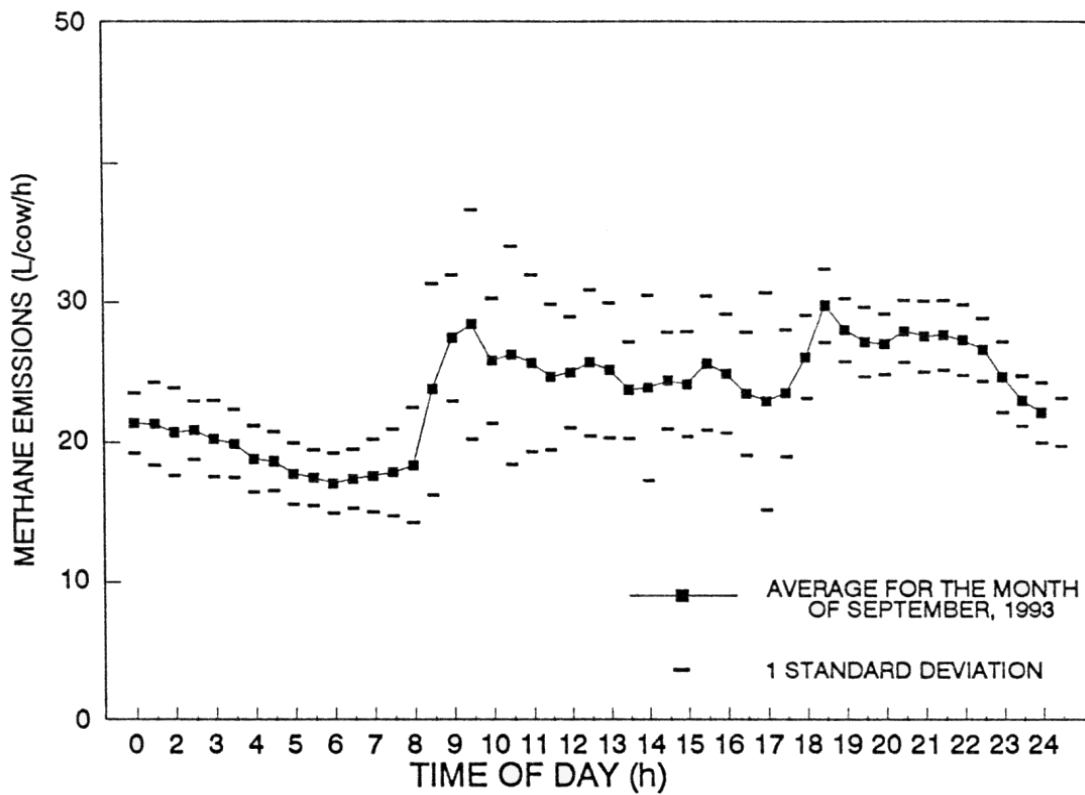

Figure 5. Emissions of methane and carbon dioxide from April, 1993 to November, 1993

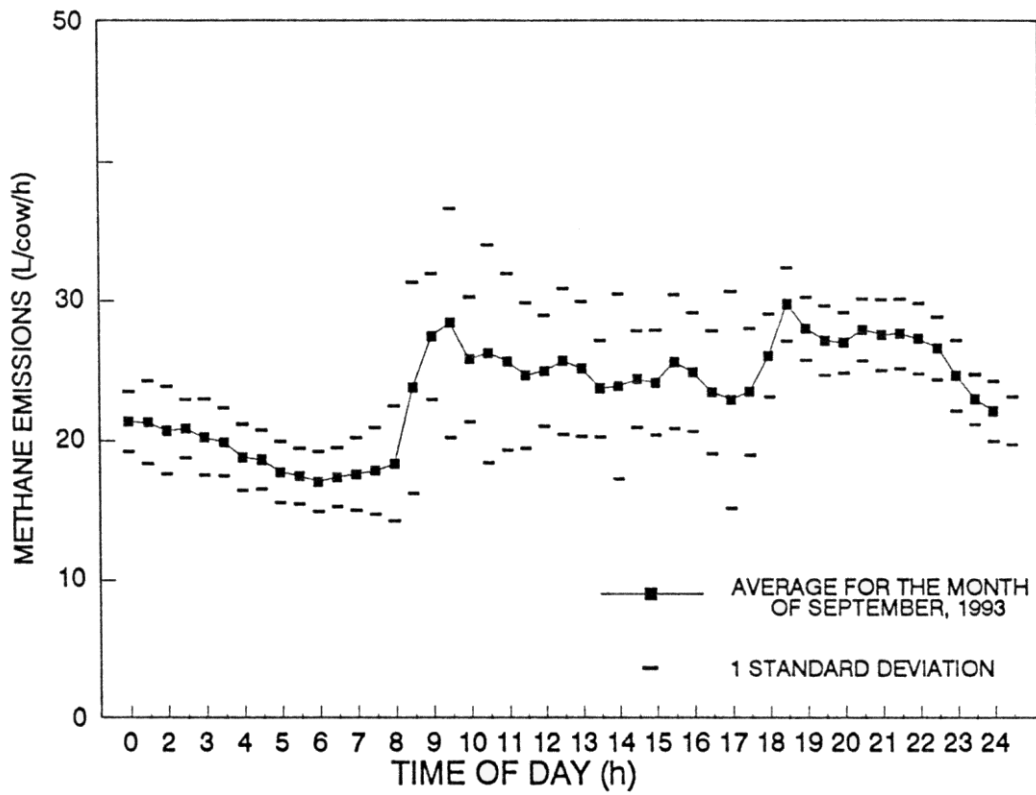

Figure 6. Diurnal pattern of methane emissions for the month of September, 1993

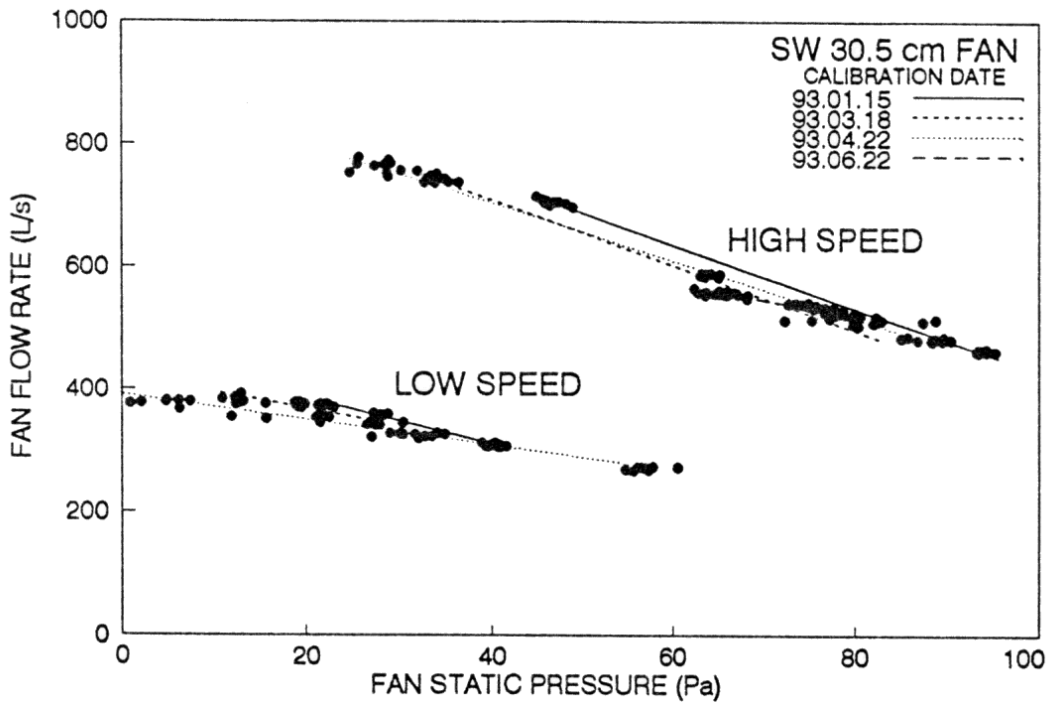

Figure 7. Fan calibration curves for the SW 30.5 cm fan